



Operation & Instruction Manual

ISSUE 1. INCLUDES 'COSHH' DATA

Important - Read first

To ensure that the Unit is used safely and responsibly, it is recommended that this manual is read by everyone using it and that the recommendations contained within are followed at all times. If there is anything you do not understand, DO NOT use this equipment, please contact Advanté Limited on 01268 280500 for advice.



INDEX

Introduction	2	Generator	14 - 15
About this Manual		Overview	
Site Selection / Preparation	3	Safety	
Location		Precautions	
Condition and Suitability		Housekeeping	
Preparation		Earth Bonding	
Lifting and Positioning	3 - 4	Daily Checks	
Safety		How to check oil and top up (24ft only)	
Lifting Points		Auto Top-Up Oil Level (32ft only)	
Solar Power Panels		LPG Safety	16
Lifting Equipment		General Safety	
Attaching the Lifting Equipment		LPG Management	16 - 17
Lifting		Cylinders	
Manoeuvring		LPG Levels	
Lowering		Gas Bottle Connection	
Surface Condition and Levelling Legs		Changing a Cylinder	
Security	5	Gas Valves	
Windows		Set Up	
Locks		Automatic Changeover Valve	
Canteen / Kitchen	6 - 7	Checking for Leaks	
Canteen / Kitchen		EcoLogic Floor Plans (32ft)	18 - 19
Drinking Water		EcoLogic 1850	
Sink Unit		EcoLogic 1750	
Washing Water		EcoLogic 1700	
Kettle		EcoLogic 1400	
Fire Safety		EcoLogic 1400s	
Microwave Oven		EcoLogic Floor Plans (24ft)	20 - 21
Office	7	EcoLogic 850	
Desk and Chairs		EcoLogic 800	
Shower	8	EcoLogic 700,400,200	
Toilet Emptying	8	EcoLogic 410	
Water Management	8	EcoLogic Floor Plan (16ft)	22
Washing Water		EcoLogic 250	
Drinking Water		EcoMax	22
Frost Precautions	8	EcoMax Floor Plans	23 - 24
Heater		Specifications (32ft, 24ft & 16ft)	25 - 26
Fuel		Unit Size	
Drying Room /WC	9	Operational Areas (EcoLogic/EcoMax)	
Overview		Height	
Wash Hand Basin		Weight	
WC		Water Capacity	
Drying Room Light Indicator Panels		LPG	
Oasis Heating System		Rate of Energy Conversion	
(Using LPG or Mains Electric)	10	Generator	
Overview		Water Heater	
3010 & 3020 Control Panels		Additional Equipment	
Resetting the Oasis Heating System	11	Toilet	
How Much Power Can I Use?	12	Client Responsibilities	26
Lighting System	13	COSSH Sheets	
Electrical System	13 - 14	Propane Gas	27
Overview		Toilet Additive	29
Loss of 230V Power		Anti Freeze	31
230V		Lead Acid Battery	33
Solar Power		Engine Oil	35
Generator		Soap Bars	37
12V DC Power			
Inverter			
Telemetric System	14		
Telemetric System			
Curfew			

INTRODUCTION

Thank you for choosing Oasis EcoLogic or EcoMax Welfare

Advanté Limited is a leading supplier of high quality, sustainable, instant start welfare units. We work closely with our clients to create positive welfare environments for people working in construction, to reduce carbon on construction sites and have a positive impact on the community.

The Oasis EcoLogic and EcoMax welfare ranges offer an extensive range of self-contained welfare and office facilities, available in different sizes and layouts.

Why choose EcoLogic/EcoMax welfare for your site?

Health and safety

- Low noise, mainly silent running
- Hot & cold controlled running water
- 24/7 Drying room
- Full forearm hand wash basins

Sustainability

- Low carbon emissions
- Hybrid technology
- Renewable energy from solar
- Reduced running costs

Staff wellbeing

- Positive work environment
- Spacious canteen/office space
- Two toilets in one 32ft unit
- Shower options

Good neighbours

- Noise reduction
- Unit curfew system
- Professional appearance
- Reliable welfare, less disruption

Thank you for choosing Oasis Welfare for your site.

As always, we are very keen to hear your feedback to support our future product and service development.

ABOUT THIS MANUAL

The information and instructions included in this manual are provided to help you get the best possible service from your EcoLogic welfare unit or EcoMax welfare setup.

Certain information in this manual is governed by law and is subject to change without prior notice. Great care has been taken to ensure that the information is correct at the time of publication. However it is the user's sole responsibility to ensure that they fully comply with all legal requirements.

Regular inspection, servicing and periodic maintenance will ensure trouble free operation.

Advanté Limited will not accept liability for any inaccuracy or incorrectly stated legal requirements. Advanté Limited maintain a policy of continued improvement and reserve the right to change specifications without prior notice.

SITE SELECTION AND PREPARATION

Location

It is the hirer's responsibility to carry out a full risk assessment before siting and positioning the EcoLogic welfare unit.

The risk assessment should establish a safe zone including (but not limited to), ground, side and overhead hazards such as power supply and communication cables, lighting systems, drainage systems and other services.

Access to and passage around the EcoLogic welfare unit must also be considered.

Where delivery or collection services are required for the units' upkeep, you must ensure ease of safe access both for personnel and vehicles.

This procedure must be performed within your Contract Safety Plan.

If permission is required with regard to the positioning of the EcoLogic welfare unit, it is the hirer's responsibility to obtain this before delivery and use.

Conditions and Suitability

Ensure that the ground on which the unit is being sited is smooth, level and capable of with-standing the units' weight plus its load.

Where the EcoLogic welfare unit is to support the EcoMax instant site start set-up, the combined weight and dimensions must be taken into account.

Ensure that the ground is suitable for both positioning and accessing the unit as any subsidence or poor ground conditions will affect its safe use and operation.

Preparation

Once a suitable site has been chosen and approved, the area should be made ready. Clear the ground area, where the EcoLogic welfare unit is to be used, of all obstructions. Decide in advance which direction the EcoLogic welfare unit should be facing.

Whether the EcoLogic welfare unit is being delivered or collected, use suitable barriers and tape to create a safe zone which will keep bystanders and unauthorised persons away during the loading/unloading process.

LIFTING AND POSITIONING

Safety

The EcoLogic welfare unit may only be lifted and positioned by suitably trained personnel, using correctly rated and certified lifting equipment.

NEVER drag or pull the unit across the ground, it MUST always be lifted.

Switch the generator OFF and close all gas valves. Secure any LPG bottles by chain.

Switch OFF the water heater and pack away the microwave, oven and kettle. (Place on floor).

Lower all toilet seats then close all internal doors. Close all windows and window shutters and lock all external doors.

Damage caused by incorrect lifting practices will be charged for and the unit will remain on hire until all repairs are completed.

Lifting Points

The EcoLogic welfare unit must ONLY be lifted via the designated lifting points. There are two options; both require the use of suitable chains.

You may use a set of four leg chain slings attached to the lifting points found in each roof corner. Alternatively it can be lifted using suitable chains connected to the four low level lifting eyes located along the bottom rail. (When lifting from the low level lifting eyes, long chains can be used as the roof is strengthened to take the load).

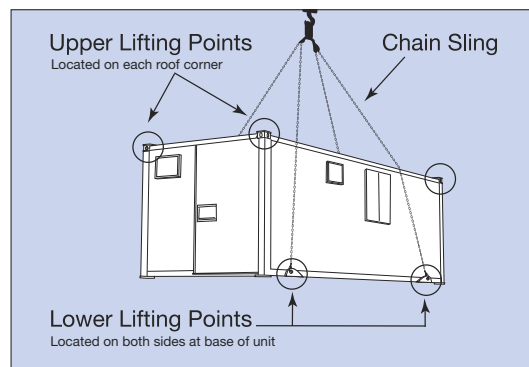

Whichever lifting point is selected, ALL four points must be used during a lift.

LIFTING AND POSITIONING (CONTINUED)

Solar Power Panels

The EcoLogic welfare unit has 2 solar power panels fitted to the roof as part of the stored power charging system.

It is of the utmost importance that the panels are protected from damage during any lifting operation.

DO NOT allow the chain slings to be lowered or dropped onto the solar panels. Any damage will be the responsibility of the hirer and is chargeable.

Note: Damage of any level (minor or major) to a panel cannot be repaired and will be charged for as a full replacement cost.

Lifting Equipment

You will require a lifting device (crane) and suitable lifting chains.

When lifting via the four roof corners, you will need a four leg chain sling fitted with hooks and safety catches. Note that most chain slings safe working load are rated at 90 degrees and the safe working load usually decreases, depending upon the angle the chain is used at. When lifting via the low level lifting eyes you will need chain slings with suitable spreader beams. Always check and obtain official confirmation from the lifting equipment supplier that it is both suitable in safe working load and chain/beam length.

Attaching the Lifting Equipment

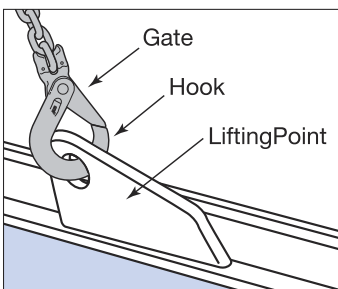

With the lifting chains correctly attached to the lifting equipment, attach each hook to a lifting point, one in each corner or each low level lifting eye. Once attached, ensure that each hook's gate is closed.

Prior to lifting, it may be necessary to shorten the chains at one end of the unit to balance it when raised. Determine the load's weight and centre of gravity as accurately as possible.

Attach tag lines to the base of the unit to control rotation and to assist in manoeuvring.

Lifting

Raise the chains until taut and check that the hooks are correctly positioned with gate closed and that the chains are not twisted. If a fault is found, lower the chains and reattach correctly.

Lift the unit just off of the ground and check that it is balanced and stable. Internal fittings are not evenly distributed in the unit therefore you may have to alter chain lengths to compensate.

Only once you are fully satisfied that everything is correctly and safely set up, should you continue with the lift.

DO NOT ALLOW ANYONE UNDER THE RAISED LOAD AT ANY TIME OR FOR ANY REASON.

Manoeuvring

Use suitable tag lines to help control the movement of the unit and always keep constant communication with the crane operator. Move slowly and smoothly to ensure full control of the units' whereabouts.

Lowering

Lower the unit to its required resting place using great care. Ensure that the ground area is level and stable. Caution: as the weight is taken off of the chains, ensure that they do not come into contact with the solar panels.

Surface Condition and Levelling Legs

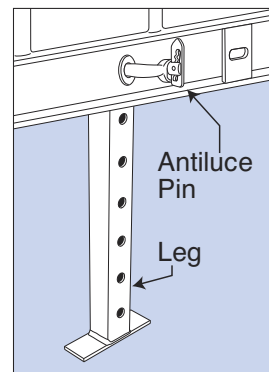

Where the surface is either soft or susceptible to damage from the units' legs, place a foot pad (available for hire) between the ground and the leg.

Maximum extension on any leg should be 500mm.

If required, set the levelling legs as necessary prior to fully lowering the unit. Release the antiluce

catch then support the leg as you extract the retaining pin. Lower the leg to the length required, then replace the pin to the nearest location hole ensuring its loop fits fully over the antiluce catch. Finally lock the antiluce catch. DO NOT use the levelling legs to increase the unit's height.

SECURITY

Windows

The canteen/kitchen and office windows have external steel shutters to protect the unit from vandalism and forced entry. The shutters are locked shut from inside the unit and once the locking bolts are retracted, the shutters open fully.

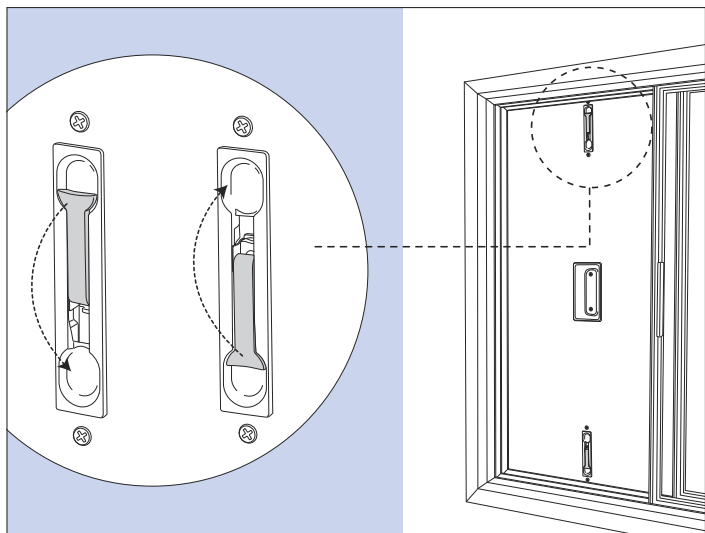

Each shutter is held in the open position by automatic catches fitted to the unit's outer skin, simply push the shutter against the catch until it clicks. The shutters must be secured when open to prevent injury to persons walking past the window. To enable opening or closing of the shutters you must firstly open the window to gain access.

To open the shutters, move the upper flush bolts' lever fully up and the lower flush bolts' lever fully down. Locking the flush bolts is simply a reversal of unlocking.

The windows slide open and the handle acts as a locking hook when closed. In addition, the windows are prevented from opening by a simple tab. To open a window, lower the tab clear then depress the handle and slide.

Windows fitted to the drying room and toilet area have a single latch bar and are protected from the outside by a security grill.

Locks

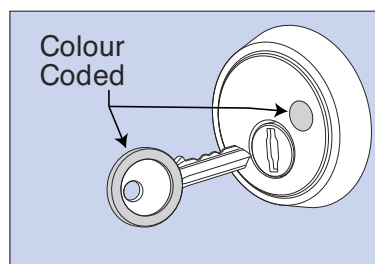

External doors to the canteen/kitchen, office, drying room, toilet and generator/LPG store are fitted with five lever dead locks which are key operated from outside but lever operated from

inside. No two locks use the same key and therefore to assist the user, each lock and matching key are colour coded.



Each lock operates a total of 9 bolts. There are 3 bolts to the main lock point, 2 to the upper edge, 2 to the lower edge and a further single bolt to the top and bottom of the door. In addition, the hinge

side of each door is fitted with security pins which engage with the door frame when closed.

To lock a door, firstly close the door fully. Next insert the correct key and turn one full revolution. Turn the key a second full revolution to 'dead lock' the door. Unlocking is simply a reverse of locking.

NB: Please be aware there are some variations in door locks.

Canteen / Kitchen

Depending upon which model of EcoLogic welfare unit you have, there will be a full size canteen or a large office with kitchen area or a separate office with a smaller canteen area. Units with a large canteen do not have the separate office space. Both versions only differ in seating capacity.

Drinking Water

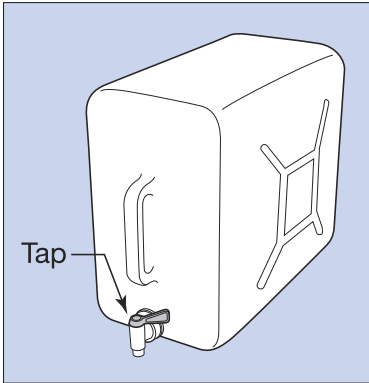

Water for drinking and cooking is supplied with the initial delivery of your EcoLogic welfare unit in two 20ltr containers. All drinking water supplied by Advanté is prepared in a controlled environment to ensure hygiene. The hirer can, at their own discretion, refill the

containers as required. However, it is the hirers' responsibility to ensure that the replacement water is fit for human consumption and that the containers remain in a hygienic state.

Sink Unit

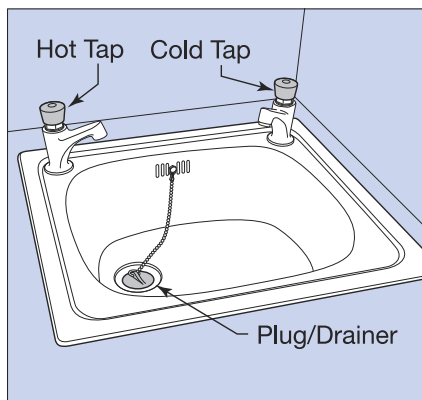

To help conserve water and avoid flooding, the taps are the push top type. To obtain water, press and hold the taps' push top, maximum flow is achieved by pressing the push top by approximately 1/2 down.

When running the hot tap, take care, as the tap body will become as hot as the water.

Washing Water

All water (hot and cold) used for washing purposes is supplied from a built-in, 400ltr storage tank. The water system is pressurised to ensure a uniform flow. Note: this water must not be used for drinking or cooking. Water levels within the storage tank are monitored constantly and if the tank becomes empty, the pump is immobilised and a warning light illuminates within the canteen/kitchen.

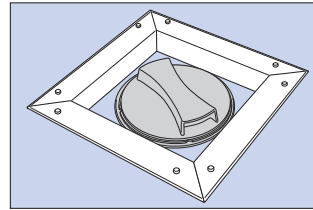

The capped filling point for the tank is located within a cutout on the canteen/kitchen worktop. The cap can be removed by turning anti-clockwise.

Fill the tank to approximately 100mm from the top using a clean hose from a fresh mains water supply. DO NOT allow the hose to be left unattended in case the hose becomes free or you exceed the tank capacity.

Note: there is an overflow fitted to the tank which discharges under the unit but if your supply water pressure delivers more water than the overflow can handle, the kitchen will flood.

Kettle

2Kw cordless kettles with base units are supplied. The base unit should only be positioned on the worktop.

Fill the kettle with fresh drinking water but do not exceed the maximum level then fully close the lid. Place the kettle on the base unit then plug the power supply cable into the nearest power point and switch the power on.

Depress the kettle's on/off switch and wait for the kettle to switch off once the water has boiled. NEVER handle electric plugs and sockets with wet hands.

Fire Safety

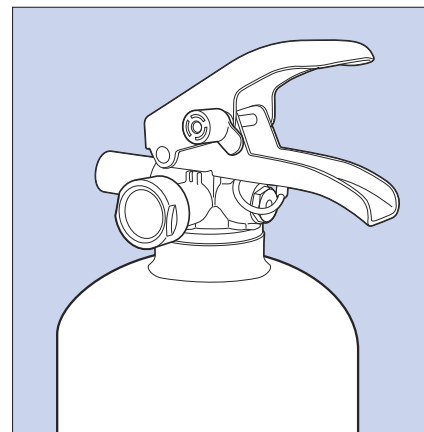

A dry powder fire extinguisher is supplied with the EcoLogic unit. It will be found in the canteen/kitchen area near the worktop.

If it is used, missing or faulty, contact Advanté for an immediate replacement.

It is the user's responsibility to organise a fire drill in case a fire should occur. All users must familiarise themselves with the position of fire fighting equipment and its correct use.

CANTEEN / KITCHEN (CONTINUED)

Microwave Oven

The model of microwave oven supplied with the EcoLogic welfare unit may vary and as such, the following information is of a general nature.

WARNING

Any person fitted with an electronic life support device (a heart pacemaker) must consult their doctor before going near or working a microwave.

Always position and operate the microwave oven on the kitchen worktop. To open the door, pull the door handle or if fitted, press the door release catch. Place any food item in a non-metallic container in the oven and close the door.

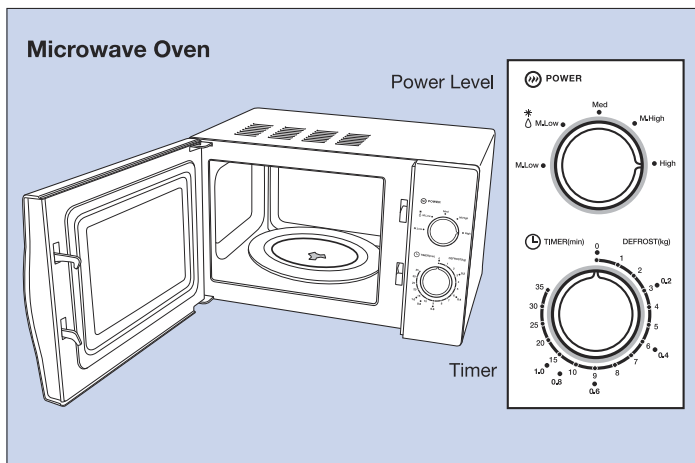

WARNING: Microwaves may not heat cooking containers directly but hot food can leave dishes hot enough to burn.

MICROWAVE SAFETY

- DO NOT** cook food in sealed containers.
- DO NOT** cook eggs in their shells.
- DO NOT** place metallic items in the oven.
- DO NOT** store items in the oven.
- DO** pierce the skins of potatoes.
- DO** keep the oven's interior clean, taking special care to remove grease and fat deposits.
- DO** double-check that the door-seal is clean and intact to minimise the risk from radiation.

Set the power levels as instructed by the food manufacturer's instructions which are usually found on the outer packaging.

Make sure the microwave oven is plugged into the power point and that the supply is switched ON. Turn the power lever control to the required setting.

Set the timer to the required cooking period and the unit will either switch ON, or you may have to press the start button.

OFFICE

Desk and Chairs

There are various office options with either an open plan office with kitchen area or a separate office and separate canteen.

Both will be supplied with office desk/s and chair/s with the number being determined by the particular layout. Whichever you have, it is your responsibility to ensure that they are kept clean and in good condition.

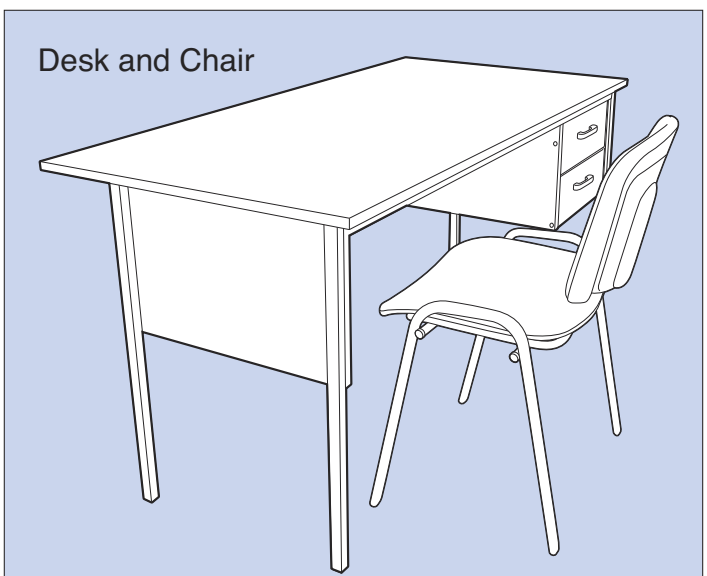

SHOWER

The EcoLogic1850 and EcoLogic 1400s models have the addition of a shower area accessed from the drying room. Operated by a push top valve, there is no requirement for a mixer tap as the water temperature is fixed.

TOILET EMPTYING

The external single WC and its wash hand basin operate in exactly the same way as the drying room WC. However, this is also where the black water tank emptying access port is. The port is covered by a cap which simply unscrews.

Emptying of the waste tank must ONLY be carried out by a licenced specialist company with the correct equipment. You can arrange for your own emptying or have Advanté arrange it for you.

NOTE: When the waste storage tank becomes full, the flushing and washing water systems are shut down to prevent the tank overflowing.

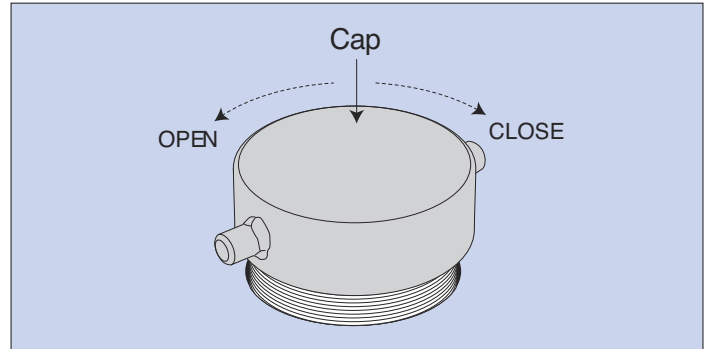

For further advice contact Advanté on 01268 280500.

WATER MANAGEMENT

Washing Water

The EcoLogic welfare unit has a water management system in place to minimise water use and therefore water wastage. The water used in this system is not suitable for drinking.

Water for washing is stored in a tank which is positioned under the kitchen/canteen work top.

All waste water produced by the kitchen/canteen sink and both toilet wash hand basins is delivered to an on-board black water storage tank.

Drinking Water

Because the on board water system is not suitable for drinking or cooking, the EcoLogic welfare unit is supplied with two full 20ltr water containers for your convenience.

FROST PRECAUTIONS

Heater

When the temperature is likely to drop, it is important to protect the units' water systems from damage caused by frost and freezing conditions.

The EcoLogic welfare unit is fitted with a sealed, wet heating system. The system is protected to a degree with a 50/50 mix of water and anti-freeze. However, during cold spells it is important that the heating remains on 24h a day to help prevent the fresh water system from freezing. The heating need only be set to 5°C to keep the room temperatures high enough to prevent freezing.

Fuel

The EcoLogic welfare unit is designed to be self-managed, that is to say, little intervention from the hirer. However, it cannot operate without a supply of LPG to run the generator and heater.

If the unit is to remain unused for a period (Christmas or Easter shut down for example) you must make sure that there is sufficient LPG in the connected cylinder.

It is important that the unit always has a constant supply of fuel at all times. Damage resulting from lack of fuel will be chargeable.

Please see 'Client Responsibilities' section of this manual for hirers responsibilities (p.26).

Overview

The drying room is fitted with coat hooks and a bench seat for personnel to dry their clothing and as a place to store them. Beneath the bench is a single radiator which is controlled by a thermostatic radiator valve.

It is also where the Oasis Heater is installed. The drying room leads to a single WC and wash hand basin.

Hand Wash Basin

To help conserve water and avoid flooding, the wash hand basin taps are of the push top type. To obtain water, half depress and hold the tap's push top. When running the hot tap, take care as the tap body will become as hot as the water.

Drying Room Light Indicator Panel (32ft unit)

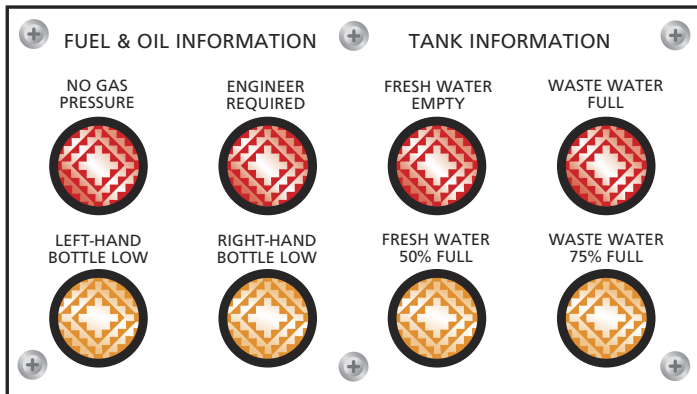

Drying Room Light Indicator Panel (24ft unit)

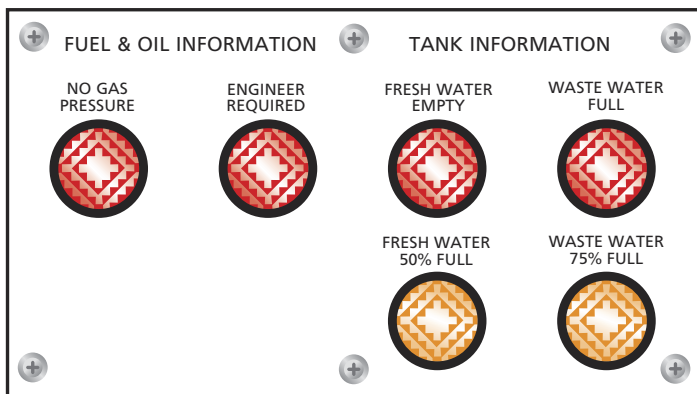

WC

The WC has a single, foot operated pedal which is used to flush the WC.

Flush will only occur when pedal is fully depressed.

Prior to and after use, you must ensure there is enough water in the bowl to cover the discharge valve.



OASIS HEATING SYSTEM (USING LPG OR MAINS ELECTRIC)

Overview

The heater is housed within the drying room and is self running. This heater supplies both hot water for washing and hot water to all the radiators. A simple sealed system, filled with antifreeze, removes the risk of damage through frost and freezing conditions.

The room thermostat and heater control panel are situated in the office or canteen if the unit does not have an office. The heater is controlled via the control panel and the next set of instructions will guide you through its settings. This system operates on both LPG and Electricity.

Note: Never turn off isolation valves on radiators in system, only adjust thermostatic valves to required temperature.

3010 Control Panel

To activate the panel from standby, press any button (once only). This will also set the back light on. The panel will indicate what aspects have been selected and whether power and gas are available.

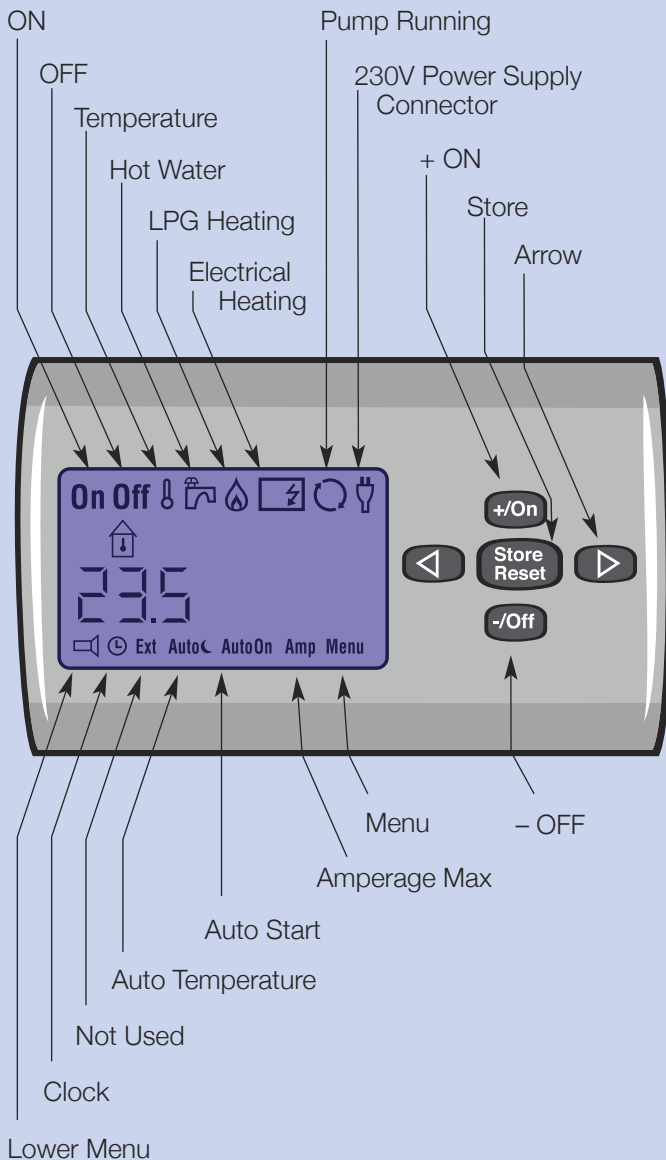

3020 Control Panel

Resetting the Oasis Heating System with Touch Screen Controls

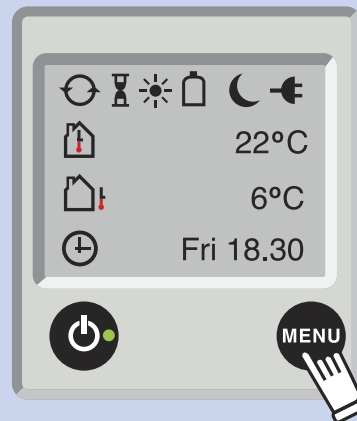

1. Press MENU button to access the Main Menu from the Standby Screen. Make sure the control panel is on.

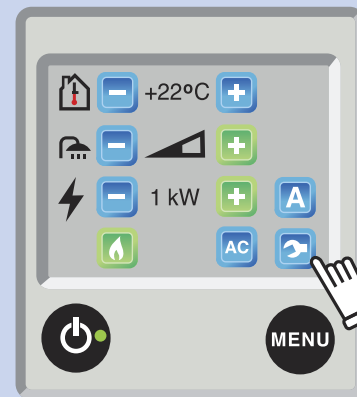

2. Press the SPANNER symbol in the bottom right hand corner



3. Press the 'Arrow up' symbol.



4. Press Reset

This will restore the system to 22°C hot water and gas heating.

RESETTING THE OASIS HEATING SYSTEM

1 Resetting The System

Press the store/reset button for 10 seconds, then press +ON.

2 Start The Heater

As '1' or if it says OFF, press + ON.

3 Switching The Heater OFF

Press either arrow button until 'ON' flashes. Press the - OFF button and OFF will flash indicating that it has been selected.

4 Select The Room Temperature

Press the right hand button until the 'Thermostat' symbol flashes. Press the + ON button to increase and the - OFF button to decrease room temperature.

Selected temperature is shown to the left side of the display. We recommend 20 degrees.

5 Warm Water

The water will automatically be heated to 50 degrees.

6 Heating With LPG Gas

Used to activate (fire up) the water heater.

Press either arrow button until 'flame' icon flashes and the large wording OFF appears on the right of the panel.

Press the + ON button and the large wording will change to ON. Press the - OFF button to switch this option OFF.

7 Heating With Electricity

The EcoLogic welfare unit is not equipped with an electrically heated water system unless it is connected to a mains power supply.

8 Lower Menu Activation

To display the lower menu press either arrow button until 'lower menu' icon flashes. Press the + ON button and all lower menu icons will be displayed.

9 Setting The Clock

Press either arrow button until 'clock' icon flashes.

Press the +ON button then use the +ON and -OFF buttons to select the day number. ie: 1 = Monday, 7 = Sunday.

Press the arrow key to step to the hour setting. Use the +ON and -OFF buttons to select the correct hour.

Press the arrow key to step to the minutes setting. Use the +ON and -OFF buttons to select the correct minute. Finally, press the 'store' button to save the time settings.

10 Auto Temperature Change

Press either arrow button until 'auto heat' icon flashes and the large wording OFF appears on the right of the panel.

Press the +ON button and the large wording will change to ON. Press the left button and the temperature selected will be displayed.

To increase the temperature press the +ON button, to decrease press the -OFF button.

Next press 'store' button then adjust the start time by repeating the instructions in section 9 and press the 'store' button.

Next set the stop time and press the 'store' button.

You can select which day the change is to occur by selecting the day number or select 0 to have the settings operate every day.

11 Auto Start

You can set the heater to start automatically.

Press either arrow button until 'auto on' icon flashes and the large wording OFF appears on the right of the panel and the time is displayed.

Now set the time by repeating the instructions in section 9 then press the 'store' button.

Press the +ON button and the large wording will change to ON.

12 Load Indicator

You can limit the amps being used by the heater to protect the generator and other circuits.

Press either arrow button until 'amp' icon flashes and the large wording OFF appears on the right of the panel.

Press the -OFF button and the large wording will change to a number from 5 to 17. Press the +ON or -OFF button to select the required rating.

To save fuel and run system efficiently, before leaving in the evening set heating controls to 10°C. (Heating remains on at night under battery power only, low setting means less gas used).

How much power can I use?

Do



Advanté Kettle



Advanté Microwave



Computer/Laptop



Desktop Printer

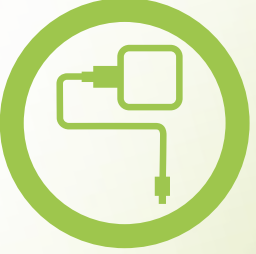

Phone Charger



Small Fridge



Water Cooler



Max combined power available 500w
 The kettle and microwave supplied by Advanté can be plugged in and used at any time. Additional electrical items can also be plugged in, but when used together they **must NOT exceed 500w in total.**

Don't

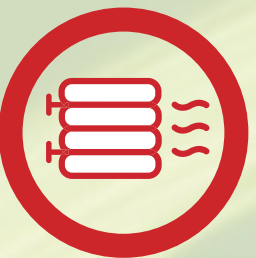

Heater



Hotplate



Power Tool



Toaster

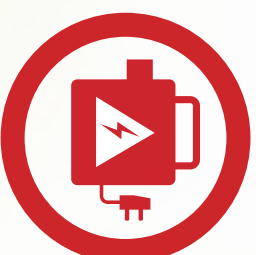

Transformer

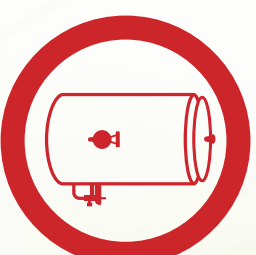

Water Boiler

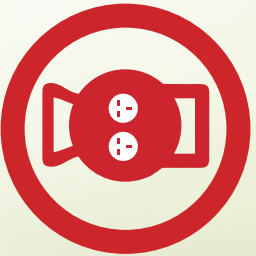

Extension Lead



For further information please contact Advanté Service Desk on 01268 280500 'option 1'

PLEASE NOTE: With EcoMax, the two units combined have the same total power available as shown above.

LIGHTING SYSTEM

The EcoLogic lighting system utilises low energy LED light units which offer good lighting levels with minimal power consumption.

To control and therefore reduce the amount of power consumed by the lighting system, each room (excluding the separate W/C) is fitted with an automatic movement sensor which switches the light on for a set period of time, when movement is detected.

ELECTRICAL SYSTEM

Overview

The EcoLogic welfare units' electrical system is designed to consume the minimum of fuel whilst maintaining a high level of service and therefore reducing your Carbon foot print.

To help achieve this, all power required to operate the various services and equipment is supplied from stored power. The level of stored power is maintained automatically by a complex management system that utilises both generated power and solar power.

Using a stored power system enables all 230V power to be constant and free from power surges and drops.

Loss of 230 Volt Power

There are two systems in place which will protect the unit from overloads.

The EcoLogic welfare unit is designed to allow an additional 500W of power consumption above the maximum required to run all supplied/fitted services at any one time. However, if you exceed the 500W, the system will shut down.

The overload protection is necessary to protect the system against damage from overloading and to ensure that the EcoLogic welfare unit remains environmentally friendly.

A loss of power may also occur if the generator has failed to start when required. This is usually caused by a lack of LPG and can be remedied easily by attaching a replacement cylinder. If this occurs, please refer to the sections in this manual which deal with LPG cylinders and with restarting the generator.

230V

The 230V systems' main consumer unit with RCCB is located in the generator storage bay.

The RCCB protects all the 230V supply circuits to the canteen/kitchen and the office (where applicable). 230V power to the canteen/kitchen and office can be isolated by switching the RCCB to OFF.

CAUTION

You MUST NOT place or store any items on the roof of the EcoLogic welfare unit as damage to the solar panels may occur.

Note: Damage of any level (minor or major) to a panel cannot be repaired and will be charged for as a full replacement cost.

Solar Power

Two solar panels fitted to the roof of the EcoLogic welfare unit supply additional power to the stored power system and help to supplement the generator.

It is important that the panel surface is protected against any form of damage and that it is kept clean. Build-up of dust and dirt or a layer of snow can reduce or even stop the panels' performance.

There are two meters within the generator bay which indicate the level of charge and the KwHr being produced by each panel.

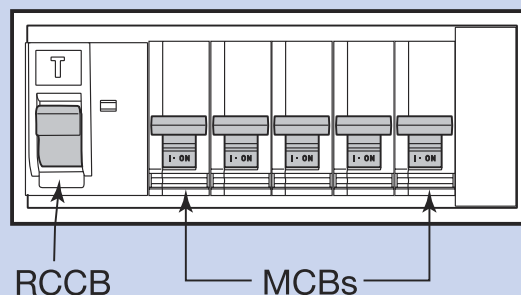

ELECTRICAL SYSTEM (CONTINUED)

Generator

The power supplied by the generator is protected by an additional RCCD unit which is fitted to the outside of the generator sound proof booth.

12V DC Power

The DC distribution board, which is also located in the generator storage bay, supplies all the DC power to the EcoLogic welfare units' operating systems, pumps and monitoring systems.

The 12V DC power supply can be isolated by turning the DC isolator switch to OFF. The switch has a simple rotary action.

Inverter

The inverter transforms DC voltage to 230V and is supplied from the stored power system. When both 230V and 12V systems are isolated, the ECU inverter is still live and needs specialist knowledge to be isolated, contact Advanté Service team if you need to isolate.

WARNING

When both 230v and 12v systems are isolated the Inverter is still live.

DO NOT attempt to carry out any work on the electrical system unless you are trained and authorised to do so.

TELEMETRIC SYSTEM

Telemetric System

Each EcoLogic welfare unit is visible from our control room. Wherever the unit is sited, information is exchanged between unit and control room. We are able to view every aspect of the unit, and set alerts for site if required.

Curfew

The operating hours of the unit are controlled by a curfew system. The curfew can be set to your specific site requirement and is both monitored and reset, if required, by our Service Team. The use of a curfew saves fuel and reduces impact on both the community and environment.

GENERATOR

Overview

The generator runs automatically and must not be started manually without guidance from the Advanté Service team.

The generator is housed within a soundproof booth to minimise noise pollution and to help manage the engines' operating temperature. The generator is fuelled by LPG (Liquefied Petroleum Gas) and managed automatically so that it is only operated when required by the system.

Safety

Before carrying out any checks or maintenance, you **MUST** read and fully understand these instructions. Failure to follow the information within this section may cause damage to the generator and put you at risk of serious injury.

Make sure you understand how to stop the generator in an emergency. **DO NOT** attempt any procedure until you have disabled the generator's auto start system to prevent it being started remotely. Make sure everyone is aware of what you are doing.

Precautions

The generator must not be operated when the acoustic side panel is removed and all guards must be in place.

Any covers such as electrical junctions must be in place. Other than when checking and replenishing engine oil levels, disconnect the engine's negative battery connection. Set the 12V breaker to OFF before carrying out any maintenance/pre-start checks.

DO NOT SMOKE

The generator bay is designated a NO SMOKING AREA.

See LPG section for additional warnings and precautions. **DO NOT** touch any part of the engine and generator when operating or immediately after it has been operating. The engine and generator become very hot during use, allow to cool sufficiently before touching any part.

GENERATOR (CONTINUED)

Housekeeping

Clean up any oil spillage immediately to prevent accidents and to maintain a clean work environment. All vents and exhaust outlets must be free from obstruction to ensure that there is a sufficient flow of air for running and cooling the engine. Make sure that fumes from the exhaust cannot be drawn back into the generator bay.

Earth Bonding

The generators windings are earth bonded unless specifically stated otherwise. The NEUTRAL and EARTH terminals of the output circuits are electrically bonded/connected within the generator. However, if you wish to have the earthing point connected to a suitable ground stake, please contact Advanté on 01268 280500 for advice.

Daily Checks

It is important for the unit to maintain fuel levels at all times. Damage resulting from lack of fuel will be chargeable.

Check gas cylinders daily to ensure sufficient fuel, see 'LPG SAFETY' (page16).

How to check oil and top up (24ft only)

To top up your oil you will need to disable the generator by popping out the chrome 12v trip switch. Remove the generator front panel, perform oil level check (See diagram below) and pop the 12v trip switch back in.

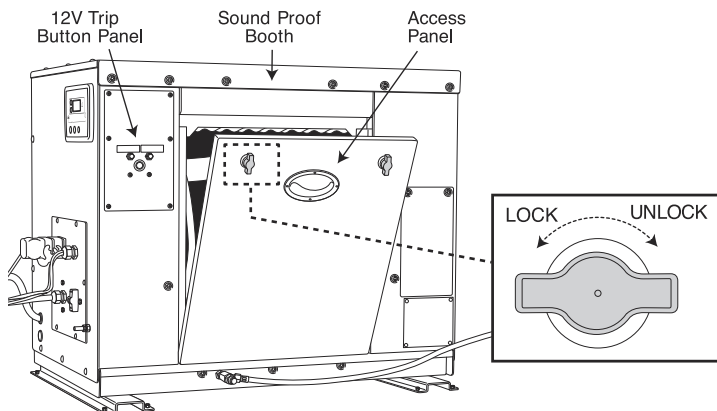

Oil Level Check

Check the engine oil level with the engine stopped and in a level position.

1. Remove the oil filler cap/dipstick and wipe it clean.
2. Insert the oil filler cap/dipstick into the oil filler neck as shown, but do not screw it in, then remove it to check the oil level.
3. If the oil level is near or below the lower limit mark on the dipstick, fill with the recommended oil (Semi Synthetic 10W-40) to the upper limit mark (bottom edge of the oil fill hole). Do not overfill.
4. Reinstall the oil filler cap/dipstick.

Note: Running the engine with a low oil level can cause engine damage.

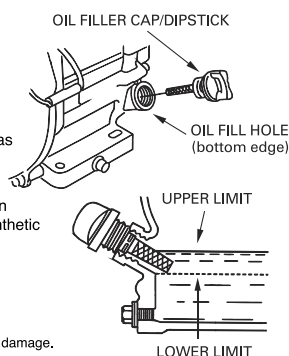

WARNING

The generator in this unit is an auto start generator and should be isolated safely prior to topping up the oil.

If your generator is fitted with an Auto Top-Up Oil System, the oil reservoir can be found inside the generator housing on the right hand side. Remove silver screw cap and top up as required.

Auto Top-up Oil level (32ft only)

If the generator is fitted with an Auto Top-Up Oil system it will monitor the engines oil level and top it up as required. Though this helps safeguard against engine damage due to lack of lubrication, the oil level indicator will require checking on a daily basis.

The oil level must be within the green band. If the level is low contact the Service Team at Advanté on 01268 280500 who will advise you how to top it up safely.

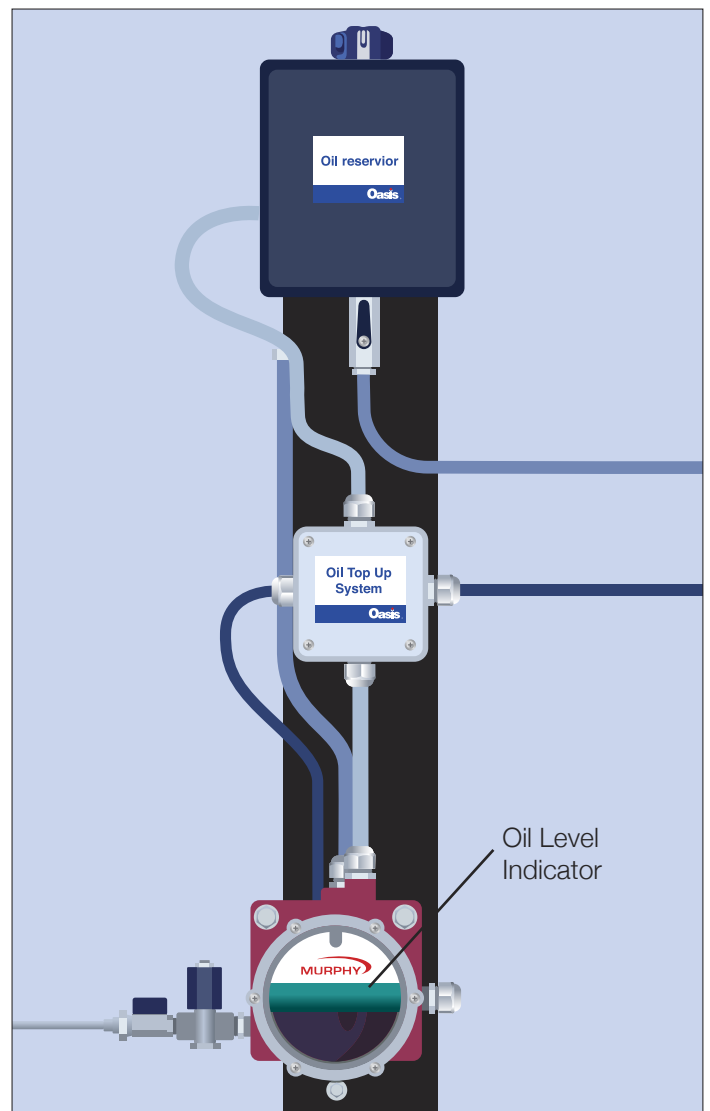

LPG SAFETY

LEGAL NOTICE

There are regulations and specific legislation which govern the transportation, storage and use of gas cylinders.

It is the user's responsibility to ensure that they are aware of all legal requirements.

General Safety

DO NOT SMOKE or use naked lights.



Wear the correct Personal Protective Equipment when handling LPG Cylinders.



Wear gloves when handling LPG cylinders and regulators.

Steel toecap boots must be worn when manoeuvring LPG cylinders.

Do not wear loose jewellery or clothing that may get in the way or become trapped in the equipment. Tie back long hair.

Inform everyone in the work area of what you are doing. Ensure adequate ventilation when using LPG cylinders.

LPG cylinders are heavy, never attempt to lift one on your own, always get help.

Always switch OFF LPG equipment and isolate it from the gas supply if not required.

Carefully inspect the LPG cylinders and equipment before use, if there is any doubt about their condition, DO NOT USE THEM.

LPG (Liquefied Petroleum Gas) is a highly flammable fuel which is stored in liquid form under pressure. LPG is heavier than air and will follow the lowest point of any floor area, so it is important that you check all equipment for leaks once connected.

Gas when mixed with air, forms a highly explosive mixture so SMOKING when near to LPG cylinders and LPG equipment MUST NOT BE ALLOWED UNDER ANY CIRCUMSTANCES.

MEDICAL WARNING

Breathing high concentrations of LPG will cause drowsiness, loss of consciousness or possibly death.

If you or your clothing become contaminated with LPG, change your clothing immediately and wash off with soap and fresh water.

LPG MANAGEMENT

Cylinders

Advanté supply two full 47kg Calor Gas Propane cylinders with the EcoLogic welfare unit, charged at the current rate. Both are stored in the LPG locker.

Advanté ONLY supply Calor cylinders and you must make sure that only Calor cylinders are returned at the end of the hire. Charges will be made for replacing missing Calor cylinders, other brands will not be accepted.

LPG Levels

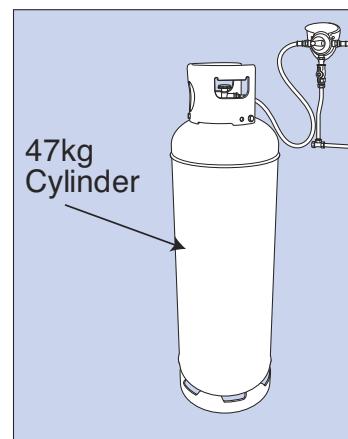

The locker is also fitted with a special weighing system that monitors the content of the cylinder (32ft only). Information on LPG levels is gathered by our telemetry system.

The locker has enough space to store an additional two cylinders to ensure continuation of supply.

Spare LPG cylinders MUST be stored with valves closed and with plastic plug fitted. You can arrange your own replacements of empty cylinders or have Advanté organise the exchange for you.

LPG MANAGEMENT (CONTINUED)

Gas Bottle Connection

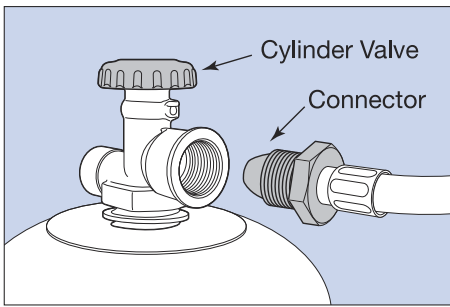

The connector fitted to the gas supply hose has a **left hand male thread** which fits directly to the cylinder's valve.

To fit the connector, firstly check that the

cylinder's valve is closed (turn clockwise) then remove the plastic plug from the cylinder valve (left hand thread, turn clockwise to release).

Most connectors have a brass mating face but you may have a connector with a rubber mating face.

Check the contact surface of the connector for scratches and general damage. The surface must be clean, dry and undamaged. Insert the connector into the cylinder valve and turn anticlockwise.

Use the spanner provided to firmly tighten the connection.

Changing a Cylinder

Close the cylinder's valve (turn clockwise). Close the main gas valve, positioned below the Automatic Changeover Valve.

Using the spanner provided, undo the connection by turning clockwise, then replace the valve's plastic plug. Release the safety chain and remove the cylinder.

Position the replacement cylinder and replace the safety chain.

Connect the new cylinder and check for leaks before opening all supply valves.

Gas Valves

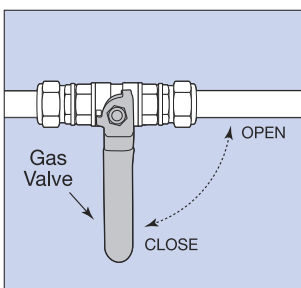

There is a gas valve for each LPG fuelled item, one for the water heater and one for the generator. Each valve is clearly marked and positioned within the generator bay. The valve is open when its lever is in line with the pipe and closed when at 90 degrees to it.

Setup

Connect both cylinders to their respective hoses as described above. Slowly open both cylinder valves.

Turn the Automatic Changeover Valve's dial so that its arrow is pointing to one of the cylinders, the arrow will show white. When this cylinder is empty, the arrow will show red and the Automatic Changeover Valve will draw from the second cylinder.

A red arrow shows an empty cylinder which should be changed. A changeover can be performed whilst the second cylinder is being used. Simply turn the Automatic Changeover Valve so its arrow is pointing to the second cylinder (this will show white), then change the cylinder as described above.

Make sure that you open the new cylinder's valve immediately after connection ready to take over from the second cylinder when it becomes empty.

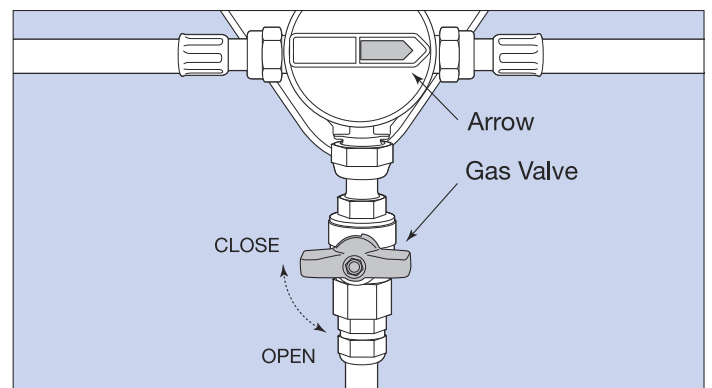

Automatic Changeover Valve

The unit's LPG system allows for two cylinders to be connected at one time.

Both cylinders are connected to an Automatic Changeover Valve which will automatically select one of the cylinders if the other is empty.

The valve has a large dial with an arrow which will show red if the cylinder is empty or white if full.

Checking for Leaks

Leaking LPG gas can be detected by smell. As a precaution, and/or if you suspect a leak, test all connections and joints with a leak detecting fluid.

If a leak is found, turn off all cylinders at their valves and disconnect the equipment, then contact Advanté on 01268 280500 for advice.

GAS LEAKS

If you suspect a leak, tell everyone in the work area and make sure no one operates any electrical switches, smokes or creates any sparks etc.

If a large amount of gas has escaped, evacuate the area and contact the emergency services.

If both bottles have been allowed to go empty, carry out task 1 on page 11, 'Resetting The System'. This will allow the heating to come back on.

ECOLOGIC 1850 (32ft)

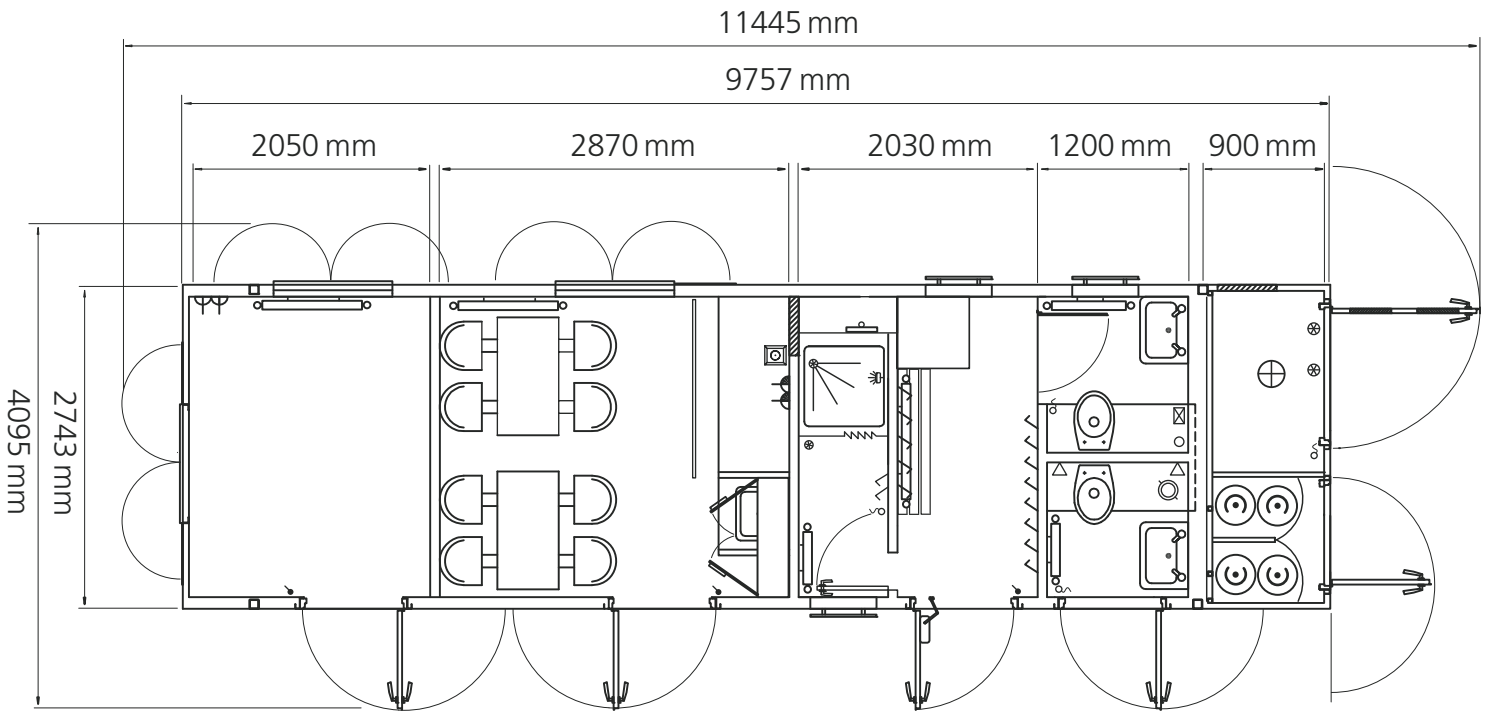

ECOLOGIC 1750 (32ft)

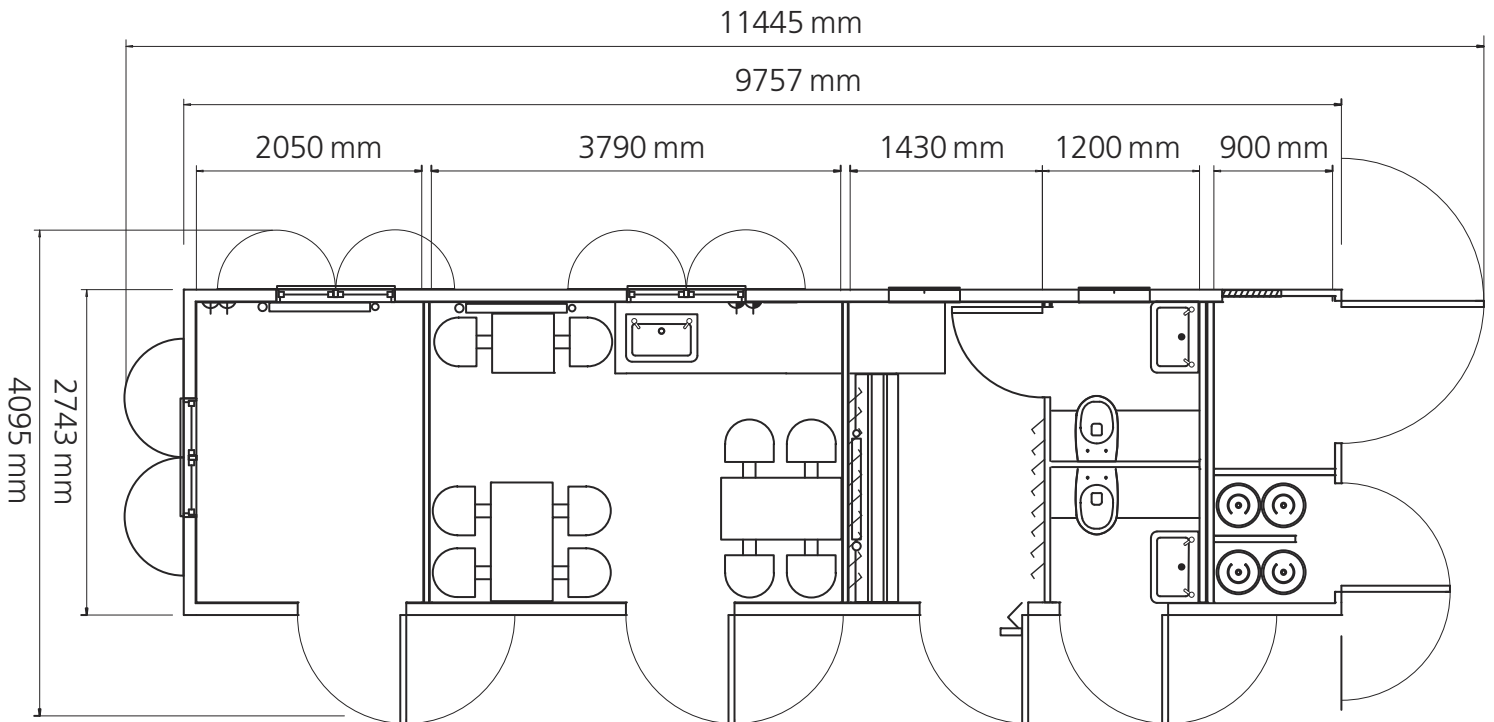

ECOLOGIC 1700 (32ft)

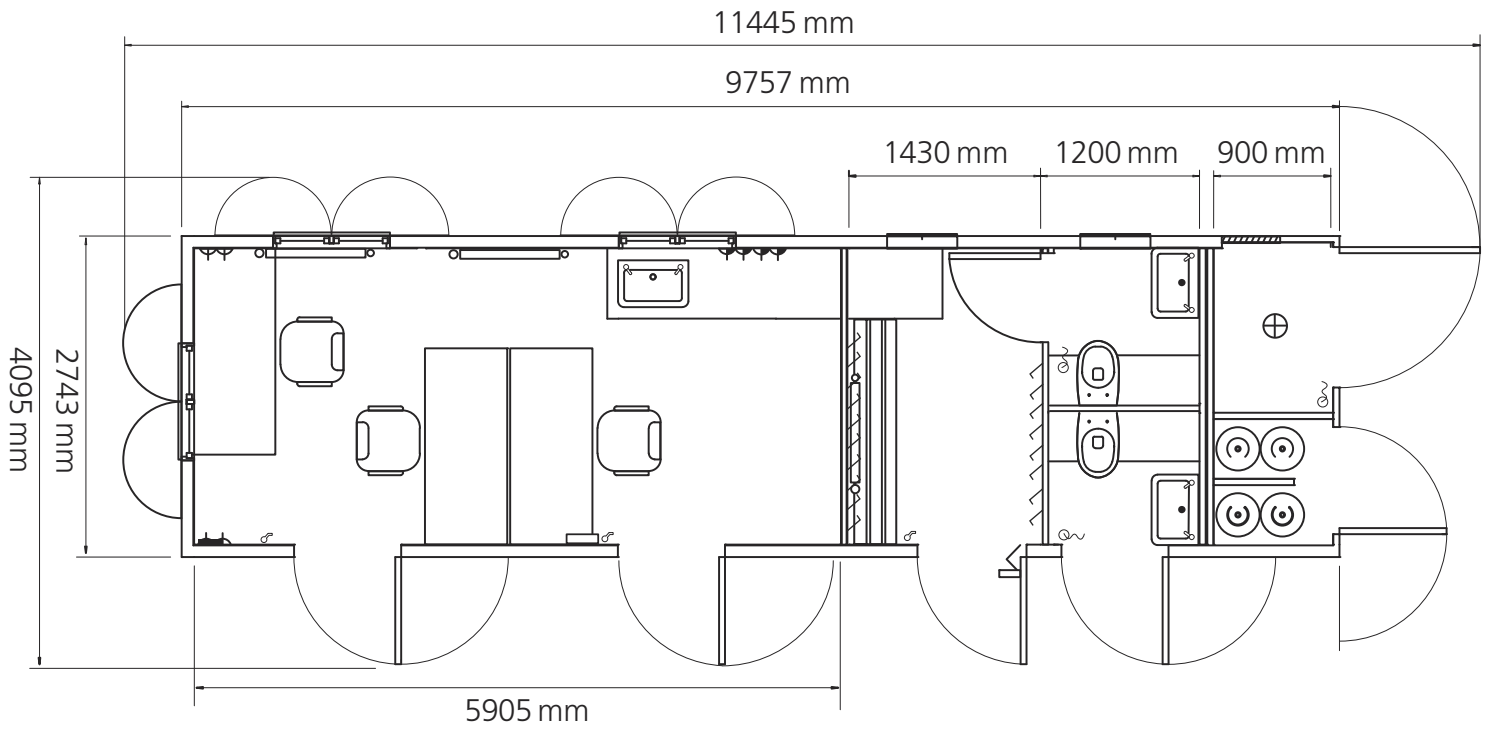

ECOLOGIC 1400 & 1400s (32ft)

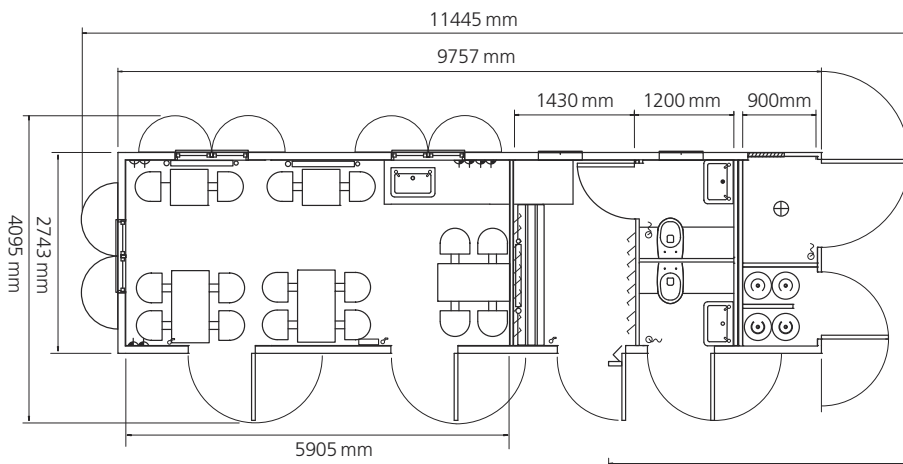

EcoLogic 1400

EcoLogic 1400s

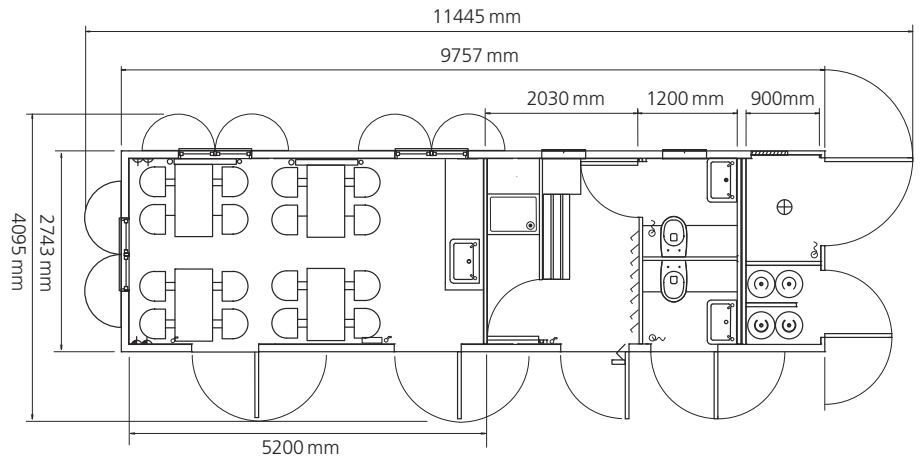

ECOLOGIC 850 (24ft)

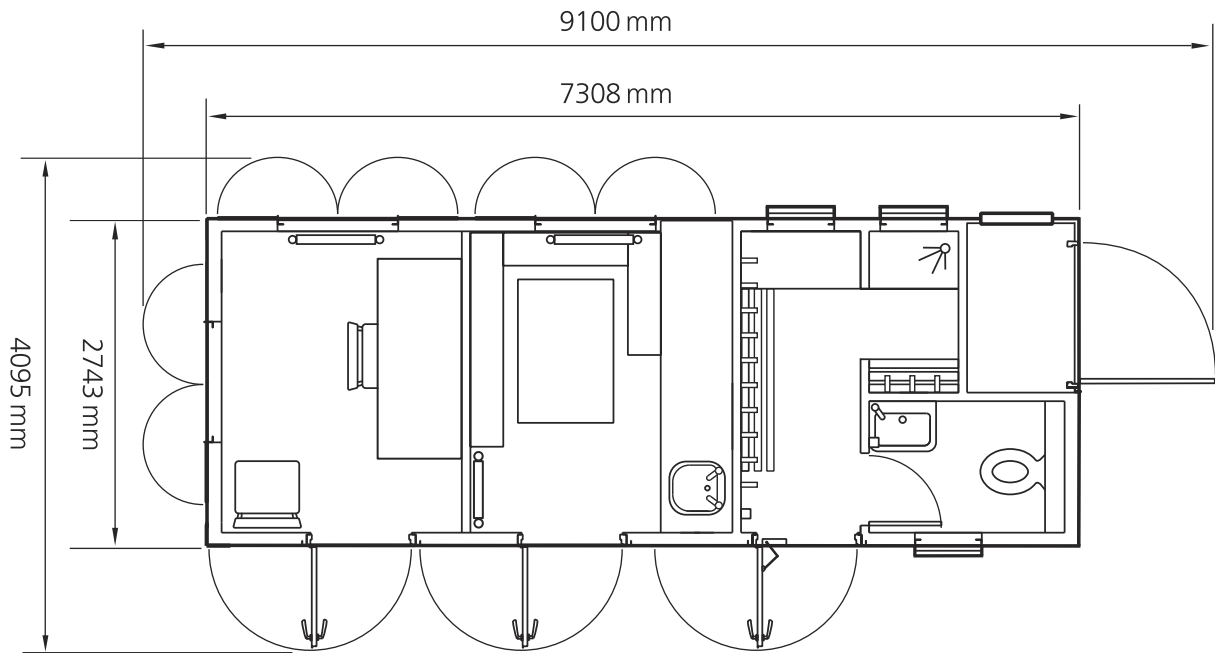

ECOLOGIC 800 (24ft)

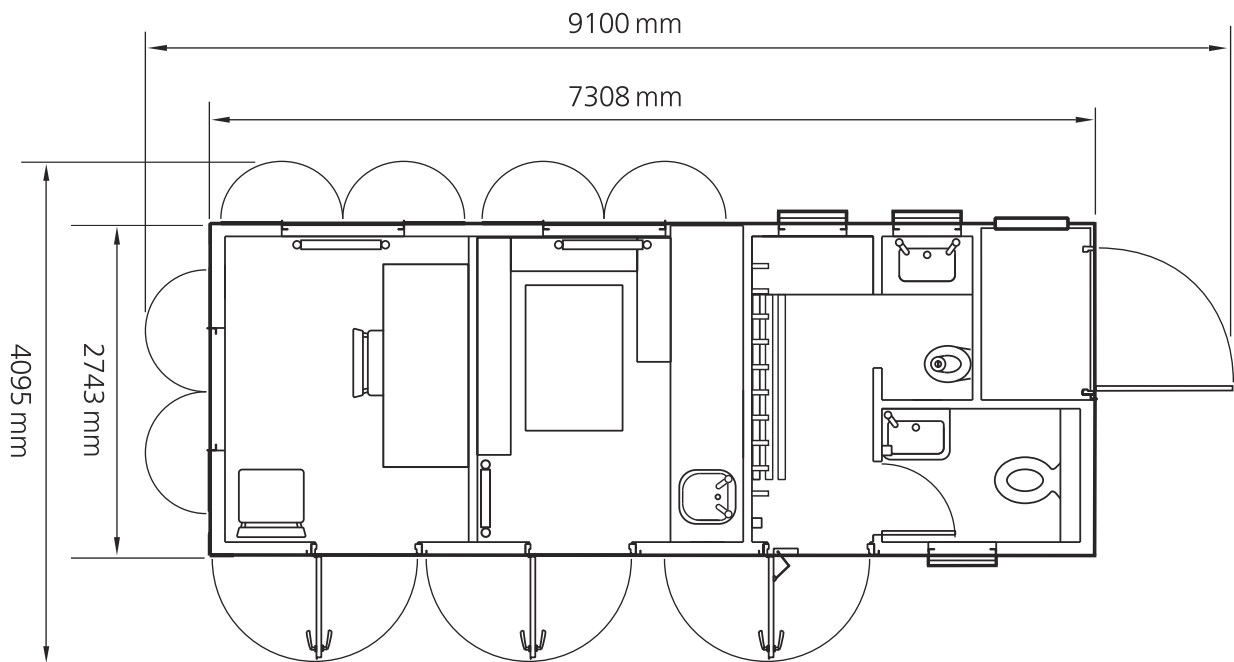

ECOLOGIC 700, 400, 200 (24ft)

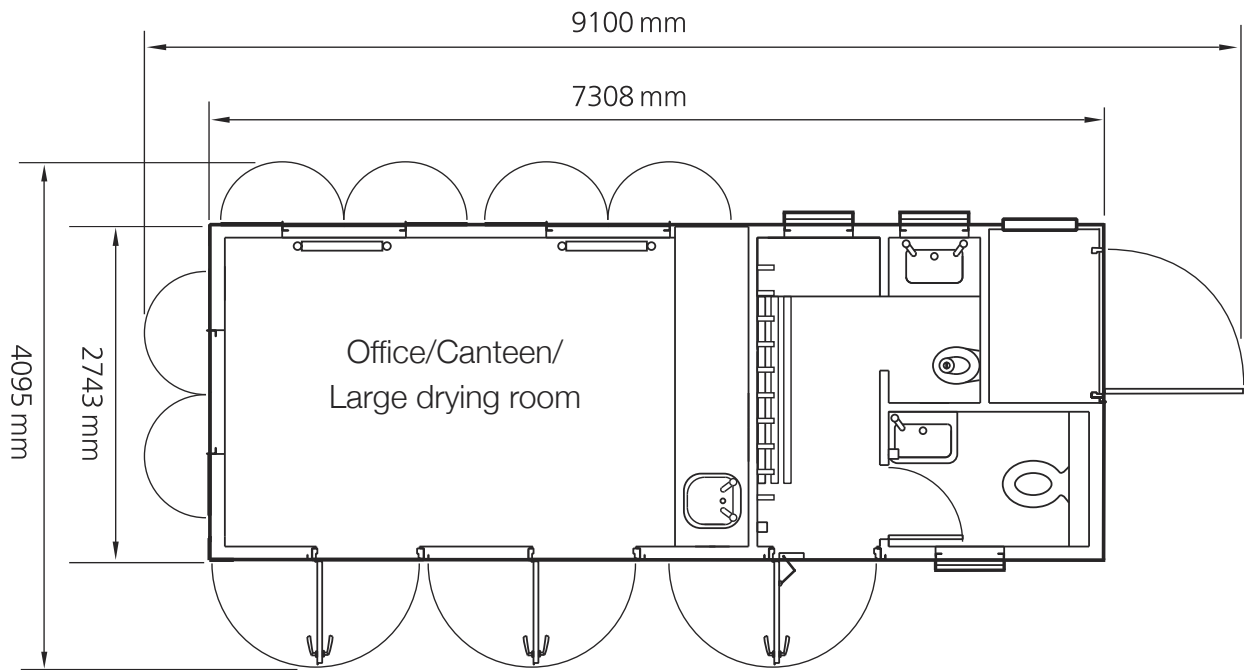

ECOLOGIC 410 (24ft)

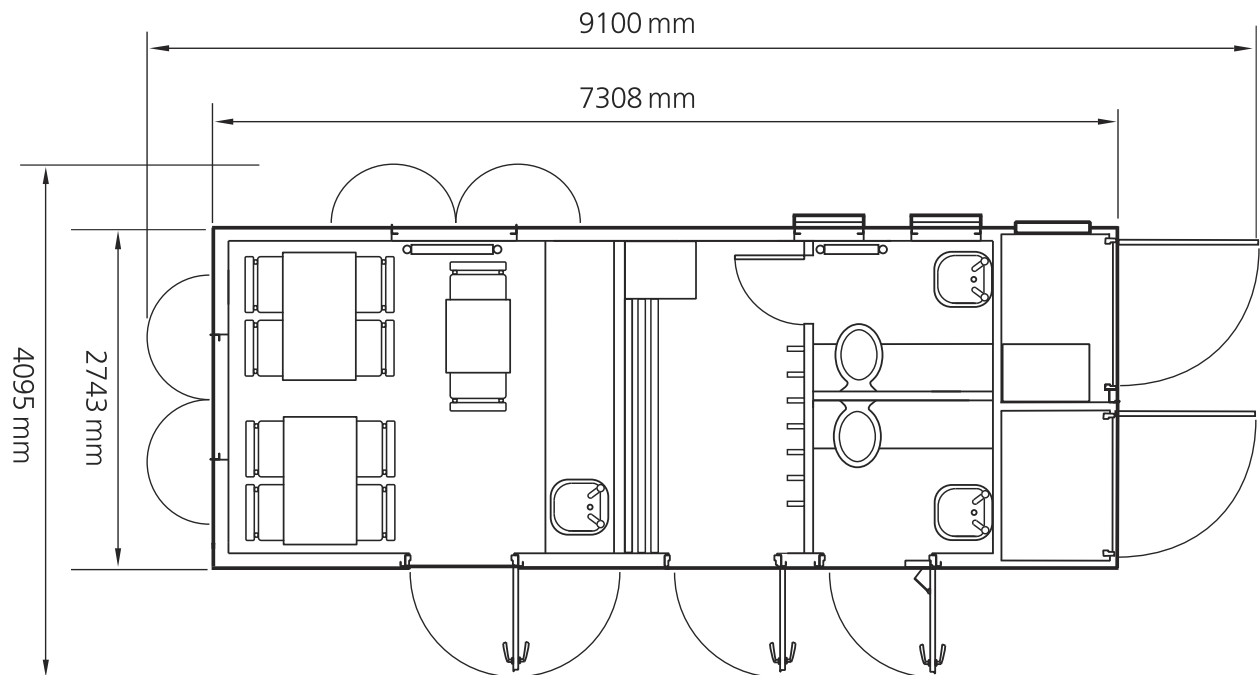

ECOLOGIC 250 (16ft)

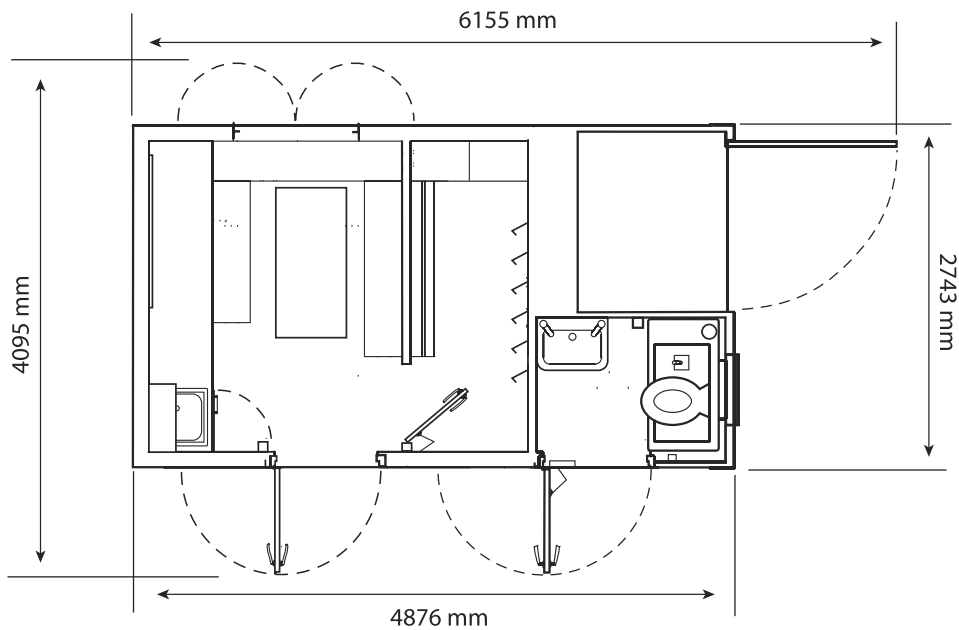

ECOMAX

The EcoMax is designed to be double-stacked by placing the EcoMax first floor unit on top of the EcoLogic ground floor unit.

The first floor unit provides additional office and/or meeting room space to the ground floor unit facilities.

Various layout options are available for the EcoMax ground floor unit by choosing from our EcoLogic model range.

The EcoMax first floor unit is powered by the EcoLogic ground floor unit.

Heating to the first floor unit is supplied independently of the ground floor unit but utilises exactly the same system design. When installed, the EcoMax will be connected to the EcoLogic's generator to maintain the power supply.

The EcoMax is fitted with solar panels, which supply additional power to the stored power system.

Access to the first floor unit of an EcoMax is via the dedicated fixed stairway.

The stairway design is such that it will block use of the EcoLogic unit's end window.

For information regarding heating, lighting and security of the EcoMax setup, please refer to the relevant sections in this manual.

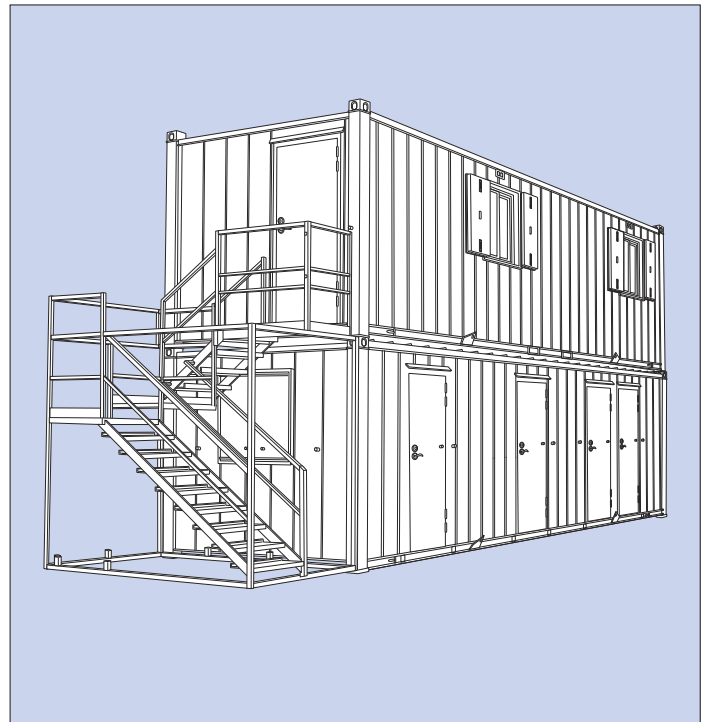

ECOMAX INSTANT START SITE SET UP (32ft)

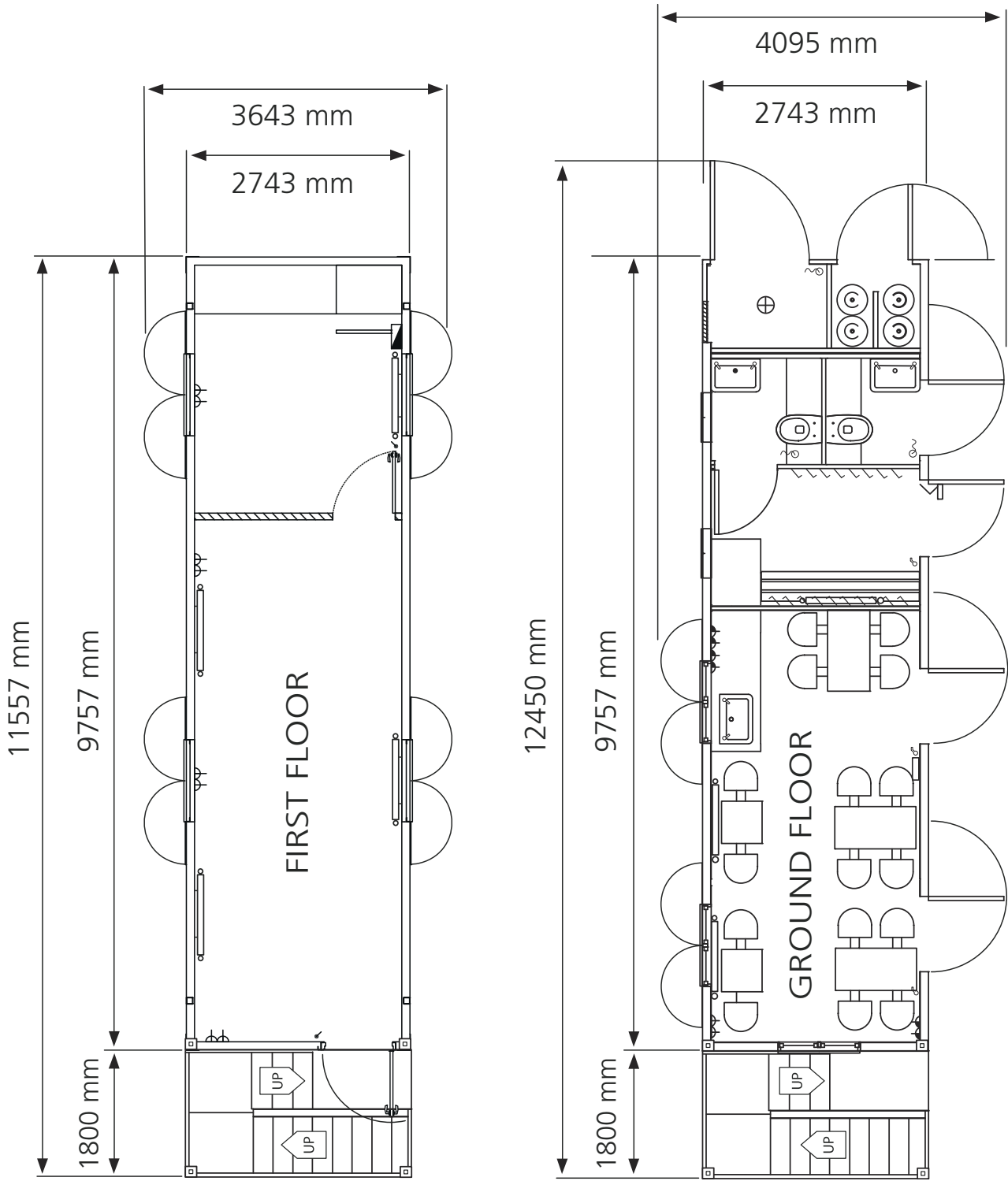

First floor: Large meeting room/office and separate office.
 Ground floor: Other layout options are available for the ground floor unit.
 See 32' EcoLogic model range.

ECOMAX INSTANT START SITE SET UP (24ft)

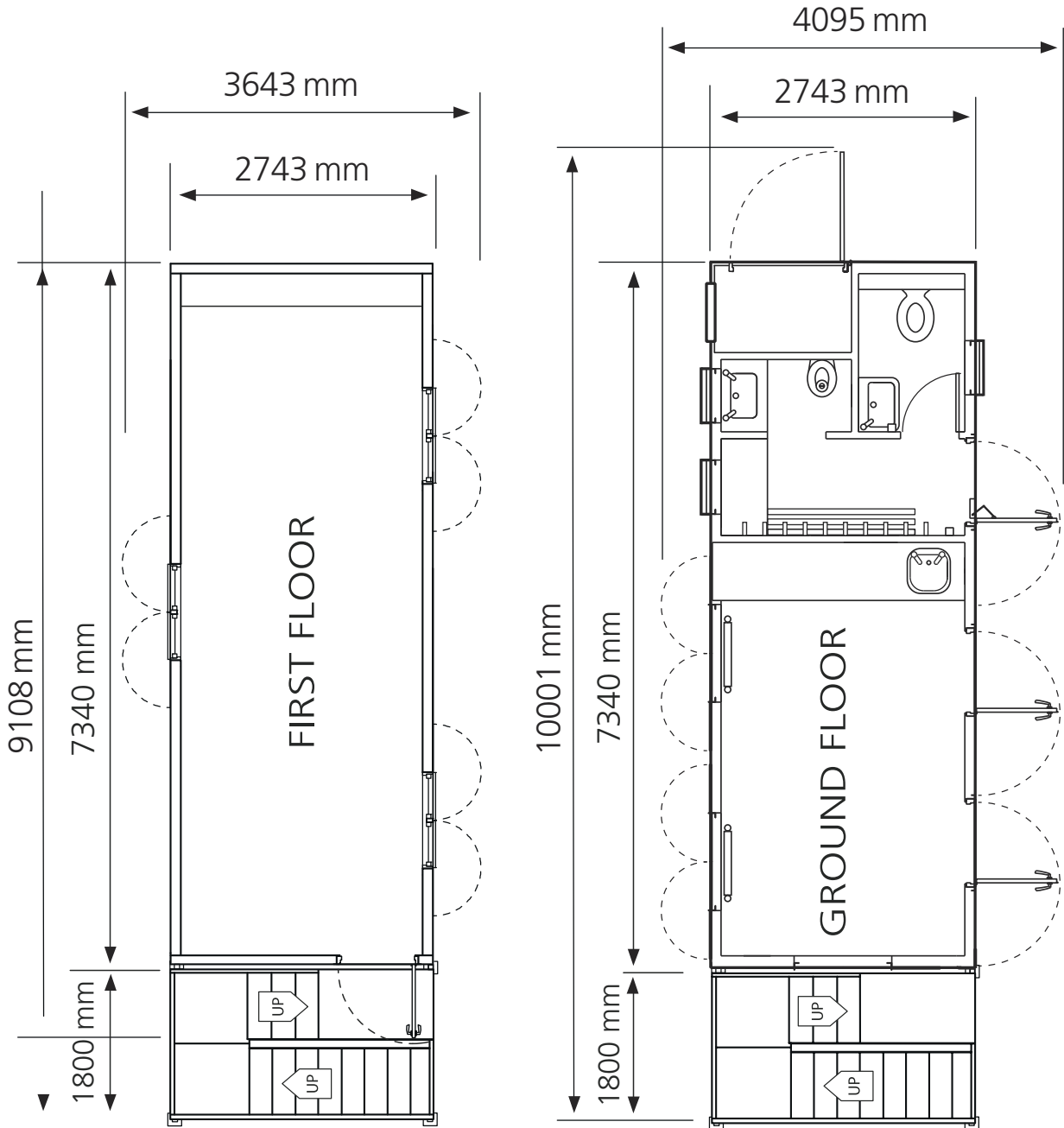

First floor: Large meeting room/office.

Ground floor: Other layout options are available for the ground floor unit.

See 24' EcoLogic model range.

SPECIFICATION (32ft)

Unit Size	9.75m x 2.7m (32ft x 9ft)
EcoLogic (operational area)	11.44m x 4.09m (37.5ft x 13.5ft)
EcoMax (operational area)	12.45m x 4.09m (41ft x 13.5ft)
Height (levelling legs closed)	2.6m (8.5ft)
Weight	7 Tonne
Water Capacity	400ltr main tank + 2 x 20ltr drinking water containers
LPG	Max storage 4 x 47kg Cylinders
Rate of Energy Conversion	135 grams of LPG per kW/H (average)
Generator	5.8 kVA LPG fuelled (0.8 power factor)
Water Heater	LPG fuelled Oasis heater
Additional Equipment	Furniture, fire extinguisher, microwave oven, kettle and notice board
Toilet	Two flushing toilets

SPECIFICATION (24ft)

Unit Size	7.3m x 2.7m (24ft x 9ft)
EcoLogic (operational area)	9.1m x 4.09m (29.9ft x 13.5ft)
EcoMax (operational area)	10m x 4.09m (32.8ft x 13.5ft) including stairs
Height (levelling legs closed)	2.5m (8.2ft)
Weight	5 Tonnes
Water Capacity	400ltr main tank + 2 x 20ltr drinking water containers
LPG	Max storage 4 x 47kg cylinders
Rate of Energy Conversion	135 grams of LPG per kW/H (average)
Generator	5.8 kVA LPG fuelled (0.8 power factor)
Water Heater	LPG fuelled Oasis heater
Additional Equipment	Furniture, fire extinguisher, microwave oven, kettle and notice board (except the EcoLogic 200, which does not have a microwave or kettle).
Toilet	Flushing toilet & urinal (except the EcoLogic 410 which has two toilets).

SPECIFICATION (16ft)

Unit Size	4.88m x 2.7m (32ft x 9ft)
EcoLogic (operational area)	6.155m x 4.095m (37.5ft x 13.5ft)
Height (levelling legs closed)	2.5m (8.2ft)
Weight	5 Tonnes
Water Capacity	400ltr main tank + 2 x 20ltr drinking water containers
LPG	Max storage 2 x 47kg Cylinders
Rate of Energy Conversion	135 grams of LPG per kW/H (average)
Generator	5.8 kVA LPG fuelled (0.8 power factor)
Water Heater	LPG fuelled Oasis heater
Additional Equipment	Fixed furniture, fire extinguisher, microwave oven, kettle and notice board
Toilet	One flushing toilet

CLIENT RESPONSIBILITIES, T&C

Terms of Hire	Advanté Terms & Conditions, as per your quote. No other terms will be accepted without prior written agreement from Advanté confirmed by a letter signed by a Director of the Company. Note: The unit's principal purpose is accommodation, it is therefore classed as an item of non-mechanical plant.
Generator	The client is responsible as per the Advanté Terms & Conditions and manufacturer's recommendations for checking the engine oil level daily.
Unit Operation	The hire rate includes an allowance of 35 generator hours per week in order for the unit to operate automatically as designed. Any hours used beyond this will be charged as extra at our current rate.
LPG	The client is responsible for changing the bottles as required, space is provided for the storage of up to two additional bottles if required.
Levelling	The unit as described elsewhere will be levelled upon delivery, and the client is responsible for maintaining the unit in a level position at all times. Failure to do so could result in engine damage, which is chargeable to the client under the contract.
Waste	Only normal toilet waste must be put in the toilet. Any contamination of the waste could result in additional charges for the client.
Damage	In line with the Advanté Terms & Conditions, damage and shortages are charged to the client.
Water Refills	These are the client's responsibility.
Canteen/Electrical	Both the microwave oven and kettle within the unit are delivered to the site PAT tested. The microwave oven will also be tested for microwave emissions. It is the client's responsibility to PAT test all equipment on his site, in line with the requirements of the regulations for Portable Appliance Testing (PAT).
Clean Air Space	Always ensure there is a minimum of 600mm clear space between the air inlet and outlet for the generator and any wall or other obstruction.









COSHH Risk Assessment No: 001			
Product Name: Calor Gas Propane			
Company name: Advanté			
Describe the activity or work process. <i>(Inc. how long/how often this is carried out and quantity substance used)</i>	Fuelling Oasis Units		
Location of process being carried out?	Client locations as per hire		
Identify the persons at risk:	Advante Employees <input checked="" type="checkbox"/>	Client Employees <input checked="" type="checkbox"/>	Public <input type="checkbox"/>
Name the substance involved in the process and its manufacturer. <i>(A copy of a current safety data sheet is attached to this assessment)</i>	Calor Propane		
Classification (state the category of danger)			
<input type="checkbox"/> Toxic/danger	<input type="checkbox"/> Danger to environment	<input type="checkbox"/> Oxidiser	
<input checked="" type="checkbox"/> Warning	<input type="checkbox"/> Corrosive	<input type="checkbox"/> Explosive	
<input type="checkbox"/> Long-term health hazard	<input checked="" type="checkbox"/> Flammable	<input checked="" type="checkbox"/> Compressed gas	
Hazard Type			
<input checked="" type="checkbox"/>	<input type="checkbox"/>	<input type="checkbox"/>	<input type="checkbox"/>
Gas	Vapour	Mist	Fume
<input type="checkbox"/>	<input type="checkbox"/>	<input type="checkbox"/>	<input type="checkbox"/>
Dust	Liquid	Solid	Other (State)
Route of Exposure			
<input checked="" type="checkbox"/>	<input type="checkbox"/>	<input type="checkbox"/>	<input type="checkbox"/>
Inhalation	Skin	Eyes	Ingestion
<input type="checkbox"/>	Other (State)		
Workplace Exposure Limits (WELs) please indicate n/a where not applicable			
Long-term exposure level (8hrTWA): 1000mg		Short-term exposure level (15 mins): 1250mg	
State the Risks to Health from Identified Hazards			
EC Classification: No Known Behaviour for Carcinogenicity, Mutagenicity and Teratogenicity			
Control Measures:			
Only use in well-ventilated areas. Avoid naked flames. Avoid inhalation of vapours and when changing cylinders. When using do not eat, drink or smoke. Avoid prolonged or repeated contact with skin. Select gloves tested to a relevant standard (EN374). Personal hygiene is a key element of effective hand care. Gloves must only be worn on clean hands. After using gloves, hands should be washed and dried thoroughly. Wear safety glasses or full-face shield if splashes are likely to occur. Safety Phrases:			

COSHH

S2 Keep out of the reach of children
 S36/37 Wear suitable protective clothing and gloves
 S61 Avoid release to the environment. Refer to special instructions / safety data sheets

Is health surveillance or monitoring required? Yes No

Personal Protective Equipment *(state type and standard)*

 <input type="checkbox"/> Dust mask		 <input type="checkbox"/> Visor	
 <input type="checkbox"/> Respirator		 <input type="checkbox"/> Goggles	
 <input checked="" type="checkbox"/> Gloves	EN 374 – protection against chemicals & micro-organisms	 <input type="checkbox"/> Overalls	
 <input type="checkbox"/> Footwear		 <input type="checkbox"/> Other	

First Aid Measures

Inhalation: Remove the affected person to fresh air. If breathing but unconscious place in recovery position. If breathing has stopped apply artificial respiration. If heartbeat absent give cardiac massage. Monitor breathing and pulse. Obtain medical assistance immediately.
Skin: When using high-pressure equipment, injection of product under the skin can occur. If high-pressure injuries occur, the casualty should be sent immediately to hospital. Do not wait for symptoms to develop.
Eyes: Flush the eye with copious quantities of water. If irritation persists refer for medical attention.
Ingestion: DO NOT INDUCE VOMITING. Protect airway if vomiting begins. Give nothing by mouth. If breathing but unconscious, place in recovery position. If breathing has stopped, apply artificial respiration. **OBTAIN MEDICAL ATTENTION IMMEDIATELY.**

Storage

Storage: In ambient temps. This product must never be stored in areas other than those allocated specifically for the storage of gas – ventilated gas locker and connect following the instructions provided with the Oasis unit.

Disposal of Substances & Contaminated Containers

Hazardous Waste Skip Return to Depot Return to Supplier Other
 (If Other Please State):
Please refer to gas exchange

Is exposure adequately controlled? Yes No









Risk Rating Following Control Measures

High Medium Low

Assessed By: RMc Date: June 2022











COSHH Risk Assessment No: 002			
Product Name: Elsan 12% Toilet Additive			
Company name: Advanté			
Describe the activity or work process. <i>(Inc. how long/ how often this is carried out and quantity substance used)</i>	Used as toilet additive in the preparation of Oasis units and added following toilet servicing conducted by Advanté contractors		
Location of process being carried out?	Client locations as per hire		
Identify the persons at risk:	Advanté Employees <input checked="" type="checkbox"/>	Client Employees <input checked="" type="checkbox"/>	Public <input type="checkbox"/>
Name the substance involved in the process and its manufacturer. <i>(A copy of a current safety data sheet is attached to this assessment)</i>	Elsan 12% Toilet Additive		
Classification (state the category of danger)			
 <input type="checkbox"/> Toxic/danger	 <input type="checkbox"/> Danger to environment	 <input type="checkbox"/> Oxidiser	
 <input checked="" type="checkbox"/> Warning	 <input type="checkbox"/> Corrosive	 <input type="checkbox"/> Explosive	
 <input checked="" type="checkbox"/> Long-term health hazard	 <input type="checkbox"/> Flammable	 <input type="checkbox"/> Compressed gas	
Hazard Type			
<input type="checkbox"/> Gas	<input type="checkbox"/> Vapour	<input type="checkbox"/> Mist	<input type="checkbox"/> Fume
<input type="checkbox"/> Dust	<input checked="" type="checkbox"/> Liquid	<input type="checkbox"/> Solid	<input type="checkbox"/> Other (State)
Route of Exposure			
<input type="checkbox"/> Inhalation	<input checked="" type="checkbox"/> Skin	<input checked="" type="checkbox"/> Eyes	<input checked="" type="checkbox"/> Ingestion
<input type="checkbox"/> Other	(State)		
Workplace Exposure Limits (WELs) please indicate n/a where not applicable			
Long-term exposure level (8hrTWA): Not Assigned		Short-term exposure level (15 mins): Not Assigned	
State the Risks to Health from Identified Hazards			
May be harmful if ingested in quantity May cause eye irritation Skin – irritation and dermatitis may result from prolonged contact Do not breathe vapour			
Control Measures:			
Only use as directed into toilet bowl Avoid inhalation of vapours when applying to toilet When using do not eat, drink or smoke. Avoid prolonged or repeated contact with skin and eyes. Select gloves tested to a relevant standard (EN374). Personal hygiene is a key element of effective hand care. Gloves must only be worn on clean hands. After using gloves, hands should be washed and dried thoroughly. Wear safety glasses or full-face shield if splashes are likely to occur. Safety Phrases:			

COSHH









S2 Keep out of the reach of children S36/37 Wear suitable protective clothing and gloves S61 Avoid release to the environment. Refer to special instructions / safety data sheets			
Is health surveillance or monitoring required? Yes <input type="checkbox"/> No <input checked="" type="checkbox"/>			
Personal Protective Equipment <i>(state type and standard)</i>			
 <input type="checkbox"/> Dust mask		 <input type="checkbox"/> Visor	
 <input type="checkbox"/> Respirator		 <input checked="" type="checkbox"/> Goggles	
 <input checked="" type="checkbox"/> Gloves	EN 374 – protection against chemicals & micro-organisms	 <input type="checkbox"/> Overalls	
 <input type="checkbox"/> Footwear		 <input type="checkbox"/> Other	
First Aid Measures			
<p>Inhalation: Remove the affected person to fresh air. If breathing but unconscious place in recovery position. If breathing has stopped apply artificial respiration. If heartbeat absent give cardiac massage. Monitor breathing and pulse. Obtain medical assistance immediately.</p> <p>Skin: When using high-pressure equipment, injection of product under the skin can occur. If high-pressure injuries occur, the casualty should be sent immediately to hospital. Do not wait for symptoms to develop.</p> <p>Eyes: Flush the eye with copious quantities of water. If irritation persists refer for medical attention.</p> <p>Ingestion: DO NOT INDUCE VOMITING. Protect airway if vomiting begins. Give nothing by mouth. If breathing but unconscious, place in recovery position. If breathing has stopped, apply artificial respiration. OBTAIN MEDICAL ATTENTION IMMEDIATELY.</p>			
Storage			
<p>Storage: Elsan Toilet Additive is entered into the toilet system by Advanté during unit preparation – additional treatments will be made by Toilet Servicers when completing Toilet Service</p>			
Disposal of Substances & Contaminated Containers			
<p>Hazardous Waste <input type="checkbox"/> Skip <input checked="" type="checkbox"/> Return to Depot <input checked="" type="checkbox"/> Return to Supplier <input type="checkbox"/> Other <input type="checkbox"/></p> <p>(If Other Please State):</p>			

Is exposure adequately controlled?	Yes <input checked="" type="checkbox"/> No <input type="checkbox"/>
Risk Rating Following Control Measures	
High <input type="checkbox"/>	Medium <input type="checkbox"/> Low <input checked="" type="checkbox"/>

Assessed By: RMc	Date: June 2022
------------------	-----------------











COSHH Risk Assessment No: 003			
Product Name: JCB Anti-Freeze			
Company name: Advanté			
Describe the activity or work process. <i>(Inc. how long/ how often this is carried out and quantity substance used)</i>	Used as anti-freeze within the sealed cooling system of Oasis generators and should not be an exposure risk to users of the unit unless cooling system leakage occurs – in this instance antifreeze will have a 50% dilution with water. Level adjustment is undertaken by Advanté Service Engineers		
Location of process being carried out?	Client locations as per hire		
Identify the persons at risk:	Advanté Employees <input checked="" type="checkbox"/>	Client Employees <input checked="" type="checkbox"/>	Public <input type="checkbox"/>
Name the substance involved in the process and its manufacturer. <i>(A copy of a current safety data sheet is attached to this assessment)</i>	JCB Anti Freeze		
Classification (state the category of danger)			
 <input type="checkbox"/> Toxic/danger	 <input type="checkbox"/> Danger to environment	 <input type="checkbox"/> Oxidiser	
 <input checked="" type="checkbox"/> Warning	 <input type="checkbox"/> Corrosive	 <input type="checkbox"/> Explosive	
 <input checked="" type="checkbox"/> Long-term health hazard	 <input type="checkbox"/> Flammable	 <input type="checkbox"/> Compressed gas	
Hazard Type			
<input type="checkbox"/> Gas	<input type="checkbox"/> Vapour	<input type="checkbox"/> Mist	<input type="checkbox"/> Fume
<input type="checkbox"/> Dust	<input checked="" type="checkbox"/> Liquid	<input type="checkbox"/> Solid	<input type="checkbox"/> Other (State)
Route of Exposure			
<input type="checkbox"/> Inhalation	<input checked="" type="checkbox"/> Skin	<input checked="" type="checkbox"/> Eyes	<input checked="" type="checkbox"/> Ingestion
<input type="checkbox"/> Other	(State)		
Workplace Exposure Limits (WELs) please indicate n/a where not applicable			
Long-term exposure level (8hrTWA): 10 mg/m ³ (Sk) – non diluted		Short-term exposure level (15 mins): 104 mg/m ³ (Sk) – non diluted	
State the Risks to Health from Identified Hazards			
Harmful if swallowed Classification Xn; R22 This chemical can be hazardous when inhaled and/or touched			
Control Measures:			
Provide adequate ventilation including Hand protection should be worn to prevent exposure to skin Goggles should be worn to prevent contact with eyes Wash contaminated clothing before re-use			
Safety Phrases:			









COSHH

S2 Keep out of the reach of children S13 keep away from food, drink and animal feed S24/25 Avoid contact with skin and eyes S46 If swallowed seek medical advice immediately S56 Dispose of this material and its container to hazardous waste point S61 Avoid release to the environment. Refer to special instructions / safety data sheets			
Is health surveillance or monitoring required? Yes <input type="checkbox"/> No <input checked="" type="checkbox"/>			
Personal Protective Equipment (state type and standard)			
 <input type="checkbox"/> Dust mask		 <input type="checkbox"/> Visor	
 <input type="checkbox"/> Respirator		 <input checked="" type="checkbox"/> Goggles	
 <input checked="" type="checkbox"/> Gloves	EN 374 – protection against chemicals & micro-organisms	 <input type="checkbox"/> Overalls	
 <input type="checkbox"/> Footwear		 <input type="checkbox"/> Other	
First Aid Measures			
Inhalation: Move injured person to fresh air and keep person calm under observation. If necessary seek medical advice and bring these instructions Skin: Remove affected person from source of contamination. Remove contaminated clothing and flush with plenty of water until pain disappears. If discomfort persists seek medical attention Eyes: Immediately flush with plenty of water for up to 15 minutes. Remove any contact lenses and open eyes wide apart. Get medical attention if any discomfort continues Ingestion: DO NOT INDUCE VOMITING. Protect airway if vomiting begins. Give nothing by mouth. If breathing but unconscious, place in recovery position. If breathing has stopped, apply artificial respiration. OBTAIN MEDICAL ATTENTION IMMEDIATELY.			
Storage			
Storage: Anti-freeze is stored within the cooling system of the generator and should not have a direct access to the users of the Oasis unit. Exposure is only expected when attending to the levels of the cooling system when undertaken by an Advanté Service Engineer who follows our specific RAMS for generator servicing			
Disposal of Substances & Contaminated Containers			
Hazardous Waste <input type="checkbox"/> Skip <input type="checkbox"/> Return to Depot <input checked="" type="checkbox"/> Return to Supplier <input type="checkbox"/> Other <input type="checkbox"/> (If Other Please State):			

Is exposure adequately controlled?	Yes <input checked="" type="checkbox"/>	No <input type="checkbox"/>
Risk Rating Following Control Measures		
High <input type="checkbox"/>	Medium <input type="checkbox"/>	Low <input checked="" type="checkbox"/>











Assessed By: RMc	Date: June 2022
------------------	-----------------









COSHH Risk Assessment No: 004			
Product Name: Lead Acid Battery			
Company name: Advanté			
Describe the activity or work process. <i>(Inc. how long/ how often this is carried out and quantity substance used)</i>	This product is used for the top up of batteries before they are installed into the Oasis unit. No exposure to this substance is possible unless batteries are damaged or have been moved causing the contents to spill. All battery maintenance should be undertaken by an Advanté Service Engineer		
Location of process being carried out?	Client locations as per hire		
Identify the persons at risk:	Advanté Employees <input checked="" type="checkbox"/>	Client Employees <input type="checkbox"/>	Public <input type="checkbox"/>
Name the substance involved in the process and its manufacturer. <i>(A copy of a current safety data sheet is attached to this assessment)</i>	Electrolyte (Lead Acid Battery)		
Classification (state the category of danger)			
 <input type="checkbox"/> Toxic/danger	 <input type="checkbox"/> Danger to environment	 <input type="checkbox"/> Oxidiser	
 <input checked="" type="checkbox"/> Warning	 <input checked="" type="checkbox"/> Corrosive	 <input type="checkbox"/> Explosive	
 <input checked="" type="checkbox"/> Long-term health hazard	 <input type="checkbox"/> Flammable	 <input type="checkbox"/> Compressed gas	
Hazard Type			
<input type="checkbox"/> Gas	<input type="checkbox"/> Vapour	<input type="checkbox"/> Mist	<input type="checkbox"/> Fume
<input type="checkbox"/> Dust	<input checked="" type="checkbox"/> Liquid	<input type="checkbox"/> Solid	<input type="checkbox"/> Other (State)
Route of Exposure			
<input checked="" type="checkbox"/> Inhalation	<input checked="" type="checkbox"/> Skin	<input checked="" type="checkbox"/> Eyes	<input type="checkbox"/> Ingestion
<input type="checkbox"/> Other	(State)		
Workplace Exposure Limits (WELs) please indicate n/a where not applicable			
Long-term exposure level (8hrTWA): 1 mg/m3(Sk) – non diluted		Short-term exposure level (15 mins): 2 mg/m3(Sk) – non diluted	
State the Risks to Health from Identified Hazards			
Eye Corrosion – Corrosive Skin Corrosion – Corrosive Contact may cause irritation or severe burns. Irritating to eyes, respiratory system and skin Ingestion – Respiratory tract irritation and possible long term effects			
Control Measures:			
To be used in well ventilated areas Respiratory protection note required for normal use Eye protection should always been worn when using this substance Gloves should always be used when handling this substance If spilt on clothing wash before re-use Acid resistant apron recommended when adding water or electrolyte to batteries			

Safety Phrases: S2 Keep out of the reach of children S13 keep away from food, drink and animal feed S24/25 Avoid contact with skin and eyes S46 If swallowed seek medical advice immediately S56 Dispose of this material and its container to hazardous waste point S61 Avoid release to the environment. Refer to special instructions / safety data sheets			
Is health surveillance or monitoring required? Yes <input type="checkbox"/> No <input checked="" type="checkbox"/>			
Personal Protective Equipment (state type and standard)			
 <input type="checkbox"/> Dust mask		 <input type="checkbox"/> Visor	
 <input type="checkbox"/> Respirator		 <input checked="" type="checkbox"/> Goggles	
 <input checked="" type="checkbox"/> Gloves	EN 374 – protection against chemicals & micro-organisms	 <input checked="" type="checkbox"/> Overalls	
 <input type="checkbox"/> Footwear		 <input type="checkbox"/> Other	
First Aid Measures			
<p>Inhalation: If inhaled move to fresh air, if breathing difficulties develop seek medical attention</p> <p>Skin: Flush affected area(s) with large amounts of water using deluge emergency shower for up to 15 minutes. Remove contaminated clothing and wash before re-use</p> <p>Eyes: Immediately flush with plenty of water for up to 15 minutes. Remove any contact lenses and open eyes wide apart. Get medical attention if any discomfort continues</p> <p>Ingestion: DO NOT INDUCE VOMITING. Protect airway if vomiting begins. Give large quantities of water. If breathing but unconscious, place in recovery position. If breathing has stopped, apply artificial respiration. OBTAIN MEDICAL ATTENTION IMMEDIATELY.</p>			
Storage			
Storage: Batteries are installed in units and should not need to be accessed by site operatives only Advante Service Engineers. If damaged or have moved as result of cabin movement contact Advante.			
Disposal of Substances & Contaminated Containers			
Hazardous Waste <input type="checkbox"/> Skip <input type="checkbox"/> Return to Depot <input checked="" type="checkbox"/> Return to Supplier <input type="checkbox"/> Other <input type="checkbox"/> (If Other Please State):			

Is exposure adequately controlled?	Yes <input checked="" type="checkbox"/> No <input type="checkbox"/>
Risk Rating Following Control Measures	
High <input type="checkbox"/>	Medium <input type="checkbox"/> Low <input checked="" type="checkbox"/>

Assessed By: RMc	Date: June 2022
------------------	-----------------

COSHH Risk Assessment No: 005			
Product Name: 10w-30 Engine Oil			
Company name: Advanté			
Describe the activity or work process. <i>(Inc. how long/ how often this is carried out and quantity substance used)</i>	Used for lubrication of Oasis unit generators and provided in 1ltr containers for topping up engines should oil warning light show low oil levels within generator – spouted jug provided with unit for this task for oil to be poured into jug to prevent spillage onto generator outer casing that might cause smoke when heated or hot		
Location of process being carried out?	Client locations as per hire		
Identify the persons at risk:	Advante Employees <input checked="" type="checkbox"/>	Client Employees <input checked="" type="checkbox"/>	Public <input type="checkbox"/>
Name the substance involved in the process and its manufacturer. <i>(A copy of a current safety data sheet is attached to this assessment)</i>	10x-30 engine oil		
Classification (state the category of danger)			
 <input type="checkbox"/> Toxic/danger	 <input checked="" type="checkbox"/> Danger to environment	 <input type="checkbox"/> Oxidiser	
 <input checked="" type="checkbox"/> Warning	 <input type="checkbox"/> Corrosive	 <input type="checkbox"/> Explosive	
 <input type="checkbox"/> Long-term health hazard	 <input checked="" type="checkbox"/> Flammable	 <input type="checkbox"/> Compressed gas	
Hazard Type			
<input type="checkbox"/> Gas	<input type="checkbox"/> Vapour	<input type="checkbox"/> Mist	<input type="checkbox"/> Fume
<input type="checkbox"/> Dust	<input checked="" type="checkbox"/> Liquid	<input type="checkbox"/> Solid	<input type="checkbox"/> Other (State) _____
Route of Exposure			
<input type="checkbox"/> Inhalation	<input type="checkbox"/> Skin	<input checked="" type="checkbox"/> Eyes	<input checked="" type="checkbox"/> Ingestion
<input type="checkbox"/> Other	(State) _____		
Workplace Exposure Limits (WELs) please indicate n/a where not applicable			
Long-term exposure level (8hrTWA): 5mg/m3		Short-term exposure level (15 mins): 10mg/m3	
State the Risks to Health from Identified Hazards			
No Significant Hazard No other known hazards			
Control Measures:			
When using do not eat, drink or smoke Ensure adequate ventilation of the working area If spilled on hot surfaces do not inhale fumes Wear chemical protective clothing Do not ingest If spilled use absorbent material to wipe up to and prevent entrance to water supplies or drainage systems			









Safety Phrases: S2 Keep out of the reach of children S36/37 Wear suitable protective clothing and gloves S61 Avoid release to the environment. Refer to special instructions / safety data sheets			
Is health surveillance or monitoring required? Yes <input type="checkbox"/> No <input checked="" type="checkbox"/>			
Personal Protective Equipment (state type and standard)			
 Dust mask <input type="checkbox"/>		 Visor <input type="checkbox"/>	
 Respirator <input type="checkbox"/>		 Goggles <input checked="" type="checkbox"/>	
 Gloves <input checked="" type="checkbox"/>	EN 374 – protection against chemicals & micro-organisms	 Overalls <input type="checkbox"/>	
 Footwear <input type="checkbox"/>		 Other <input type="checkbox"/>	
First Aid Measures			
<p>Inhalation: Do not breath fumes if burnt or spilled onto hot surfaces</p> <p>Skin: Irritating to skin, wash off immediately with plenty of soap and water, remove contaminated clothing. Seek medical attention if irritation or symptoms persist</p> <p>Eyes: Irritating to eyes, rinse immediately with plenty of water for 15mins. Seek medical attention if irritation or symptoms persist</p> <p>Ingestion: DO NOT INDUCE VOMITING. Ingestion may cause nausea and vomiting. Seek medical attention if symptoms continue</p>			
Storage			
<p>Storage: The 1ltr container should be stored in the generator compartment in dry and well-ventilated areas. Keep container tightly closed and always in correctly labelled</p>			
Disposal of Substances & Contaminated Containers			
<p>Hazardous Waste <input type="checkbox"/> Skip <input type="checkbox"/> Return to Depot <input checked="" type="checkbox"/> Return to Supplier <input type="checkbox"/> Other <input type="checkbox"/></p> <p>(If Other Please State):</p>			

Is exposure adequately controlled?	Yes	<input checked="" type="checkbox"/>	No	<input type="checkbox"/>
Risk Rating Following Control Measures				
High	<input type="checkbox"/>	Medium	<input type="checkbox"/>	Low <input checked="" type="checkbox"/>

Assessed By: RMc	Date: June 2022
------------------	-----------------

COSHH Risk Assessment No: 006			
Product Name: Hand Soap Bars			
Company name: Advanté			
Describe the activity or work process. <i>(Inc. how long/ how often this is carried out and quantity substance used)</i>	The hand soap bars are for clients using the Oasis welfare units for hand and facial washing. They are not antiseptic soap bars and are for external use only.		
Location of process being carried out?	Client locations as per hire		
Identify the persons at risk:	Advante Employees <input type="checkbox"/>	Client Employees <input checked="" type="checkbox"/>	Public <input type="checkbox"/>
Name the substance involved in the process and its manufacturer. <i>(A copy of a current safety data sheet is attached to this assessment)</i>	General hand soap bars		
Classification (state the category of danger)			
 <input type="checkbox"/> Toxic/danger	 <input type="checkbox"/> Danger to environment	 <input type="checkbox"/> Oxidiser	
 <input type="checkbox"/> Warning	 <input type="checkbox"/> Corrosive	 <input type="checkbox"/> Explosive	
 <input type="checkbox"/> Long-term health hazard	 <input type="checkbox"/> Flammable	 <input type="checkbox"/> Compressed gas	
Hazard Type			
<input type="checkbox"/>	<input type="checkbox"/>	<input type="checkbox"/>	<input type="checkbox"/>
Gas	Vapour	Mist	Fume
<input type="checkbox"/>	<input type="checkbox"/>	<input type="checkbox"/>	<input type="checkbox"/>
Dust	Liquid	Solid	Other (State)
Route of Exposure			
<input type="checkbox"/>	<input type="checkbox"/>	<input checked="" type="checkbox"/>	<input checked="" type="checkbox"/>
Inhalation	Skin	Eyes	Ingestion
<input type="checkbox"/>		<input type="checkbox"/>	
Other		(State)	
Workplace Exposure Limits (WELs) please indicate n/a where not applicable			
Long-term exposure level (8hrTWA): Not Listed		Short-term exposure level (15 mins): Not Listed	
State the Risks to Health from Identified Hazards			
No Significant Hazard No other known hazards			
Control Measures:			
Avoid contact with eyes Do not ingest Safety Phrases:			
Is health surveillance or monitoring required?			
Yes <input type="checkbox"/>		No <input checked="" type="checkbox"/>	

COSHH

Personal Protective Equipment <i>(state type and standard)</i>			
 <input type="checkbox"/> Dust mask		 <input type="checkbox"/> Visor	
 <input type="checkbox"/> Respirator		 <input type="checkbox"/> Goggles	
 <input type="checkbox"/> Gloves	EN 374 – protection against chemicals & micro-organisms	 <input type="checkbox"/> Overalls	
 <input type="checkbox"/> Footwear		 <input type="checkbox"/> Other	
First Aid Measures			
Inhalation: Not applicable Skin: Not applicable Eyes: Irritating to eyes, rinse immediately with plenty of water for 15mins Ingestion: DO NOT INDUCE VOMITING. Ingestion may cause nausea and vomiting. Seek medical attention if symptoms continue			
Storage			
Storage: This product should be stored in the dry and contact with water and damp should be avoided			
Disposal of Substances & Contaminated Containers			
Hazardous Waste <input type="checkbox"/> Skip <input type="checkbox"/> Return to Depot <input checked="" type="checkbox"/> Return to Supplier <input type="checkbox"/> Other <input type="checkbox"/> (If Other Please State):			

Is exposure adequately controlled?	Yes <input checked="" type="checkbox"/> No <input type="checkbox"/>
Risk Rating Following Control Measures	
High <input type="checkbox"/>	Medium <input type="checkbox"/>
Low <input checked="" type="checkbox"/>	

Assessed By: RMc	Date: June 2022
------------------	-----------------

For your peace of mind



Head Office

Advanté Ltd, 10/11 Argent Court, Sylvan Way, Southfields Business Park, Basildon, Essex SS15 6TH

T: 01268 280500 E: sales@advante.co.uk W: www.advante.co.uk