



Hired & Managed Advisory General Method Statement – Advanté Welfare

Scope

The scope of this General Method Statement is to provide an advisory document to confirm a sequenced statement of work for our arrival on site and delivery of an Advanté 24 Ft x 9 Ft EcoMax Welfare Unit configuration in conjunction with client managed resources and site lifting plan requirements.

Our planning and controls have been developed in accordance with BS7121: 2016 Part 4 covering the provision of Hired & Managed Lifting operations in accordance with client Lifting Plans.

The sequencing outlined provides guidance on each step of this process from arrival on site, interaction with site resource, positioning of the vehicle for lifting and exiting the site post completion of the delivery.

In preparation for the new Civil Aviation Authority CAP 1096 Guidance Implementation which will occur not earlier than 1st April 2022, please notify Advanté Ltd if there are Aerodromes, Helipads or Private Landing Strips in the vicinity of the location of the enquiry and Advanté Ltd can advise on the notification process that the CAA will expect the Crane user to comply with based on the document link below.

<https://www.cpa.uk.net/news/caa-cap-1096-guidance-for-crane-users-and-associated-cpa-tin>

Collection of the EcoMax Unit's will follow the same process. This may require interaction with Advanté in advance of the planned collection date with the site resource to highlight any differences in site conditions and access that have taken place after the original delivery.

We will ensure that all lifting information including records of competence and lifting equipment inspection and test are available for the client to review and assess on site.

Abbreviations used in this document.

LLCO – Lorry Loader Crane Operator

LLC – Lorry Loader Crane

C SM – Client Site Management referring directly to the receiver of this document

C Ops – Client Site Operatives organised by the CSM

RA – Risk Assessment

GF Unit – EcoMax Ground Floor Welfare Unit

MS Unit – Modular Staircase

EM Unit – EcoMax 1st Floor Welfare Unit

1. Details of Load/confirmation of lifting radius allowed for/Corner Loadings for the location required.

Weight (inc attachments):	Ground Floor Unit – EM850 or EM800 or EM700 or EM410 or EM400 Maximum – 5000 Kgs each First Floor Unit – EM700 with End Door – 4000 Kgs EcoMax Staircase 1650 Kgs
Dimensions:	24 Ft x 9 Ft = L 7.35 M x W 2.74 M x H 2.50 M (2 x Units) L 2.73 M x W 2.43 M x H 1.80 M (1 x Staircase)
Height of Lift:	11.65 Metres to top of Jib minimum clearance needed
Max Radius:	6.3 Metres
Position of C of G:	Lower Lifting Lugs fabricated/positioned at the factory to suit the final C of G of the Unit - As per the manufacturer documentation



Caption Photo to the left is for indicative purposes ONLY of the EcoMax concept – 24 Ft EcoMax has a maximum of 3 Doors only in the Ground Floor Unit. Refer to Advanté Web Site for details

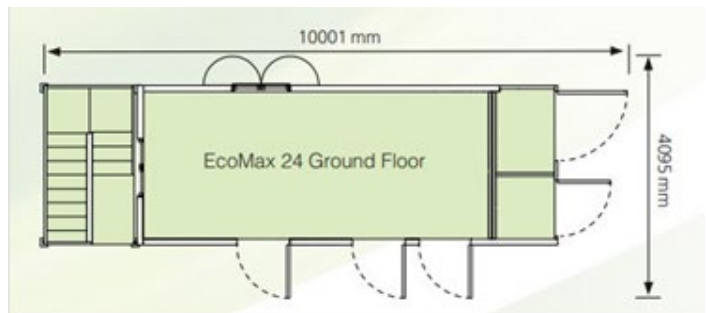

Modular Staircase lifting details – Use 3 out of 4 Chain Leg Brothers attached to fabricated lifting positions



Calculation for 7.35 Metre (24ft) EcoMax Double Stack configuration and Modular Staircase on 10 Te WLL 400 x 400mm Power Pads

	EcoMax (Heaviest end incl Hanging Modular Staircase) Base Unit Max 2230 Kgs, Top Unit Max 2000 Kgs, Staircase 1500 Kgs = Total 5730 Kgs	5730
Load per leg		
2865	Total load per leg in KG	Purpose made WLL 10 Tonnes "Power Pads" supplied with configuration
	Pad's/base plate size under legs	400 by 400 mm

	<u>DEAD LOAD ONLY</u> Pressure under each jackleg in N/m²		
2865	M _L = MASS OF TOTAL LOAD (KG) –		
28077	FORCE AT FOOT (NEWTONS) PER LEG WITHOUT PAD'S		
9.8	G = FORCE OF GRAVITY (9.8 m/s ²)		
0.16	Foot pad	0.4 X	0.4 metre
175481	Pressure under base pad in N/m ²		
	DIVIDE F₁ BY AREA OF FOOT/PAD TO GIVE FORCE IN N/m²		
175	kN/m²	This is the Pressure under one of the Corner Posts or Levelling Legs (the pair being equally loaded) at the Modular Staircase end of the EcoMax configuration, which is therefore the maximum distributed load beneath any of the 4 Power Pad's on which the EcoMax is positioned. NB NOT INCLUDING LIVE LOAD	

2. Details of Vehicle/Crane

Make & Model:	Minimum Rigid Scania 8 x 2 with 45.97 Te Metre Class Fassi F455RA 2.25 Lorry Loader Crane – Refer to capacity Chart below and Page 5
Capacity:	41.79 Te/Metre – Substitute Crane suitable for the weight and radius confirmed in Section 1
Outrigger Spread Centres:	Left to Right (X) Max 8.2 Metre Front to Back (Y) 7.3 Metres
Force through Outrigger Piston.	80840 Newton's – Refer to Page 5
Standard Mat/Pad Size:	500 mm x 500 mm Nylon Mats = 0.25 Sq M
Additional Outrigger Mat's available at additional cost:	Please refer to the quotation provided - 1.5 M x 1.2 M available.
Final maximum distributed Outrigger Load with standard Mat:	32.97 Te M Sq – Refer to Page 5
Gross Rigged Weight:	Max 36,000 Kgs

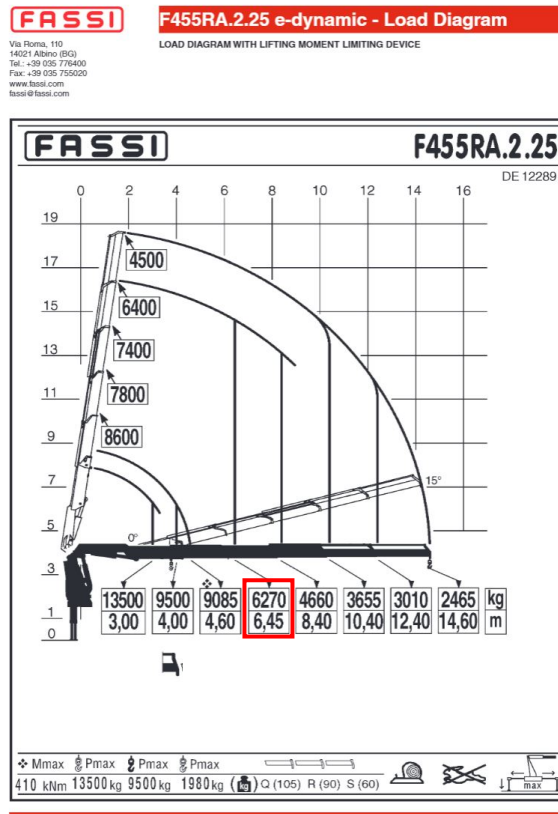



Lorry Loader
Cross Section

Required operating clearance
for Lorry Loader

11.65m (F)

Note 1

If larger pads are requested, add 250mm to required clearance for vehicle to allow for Pad Carrier. Therefore "B" will become 4.60m loaded height with Pad carrier

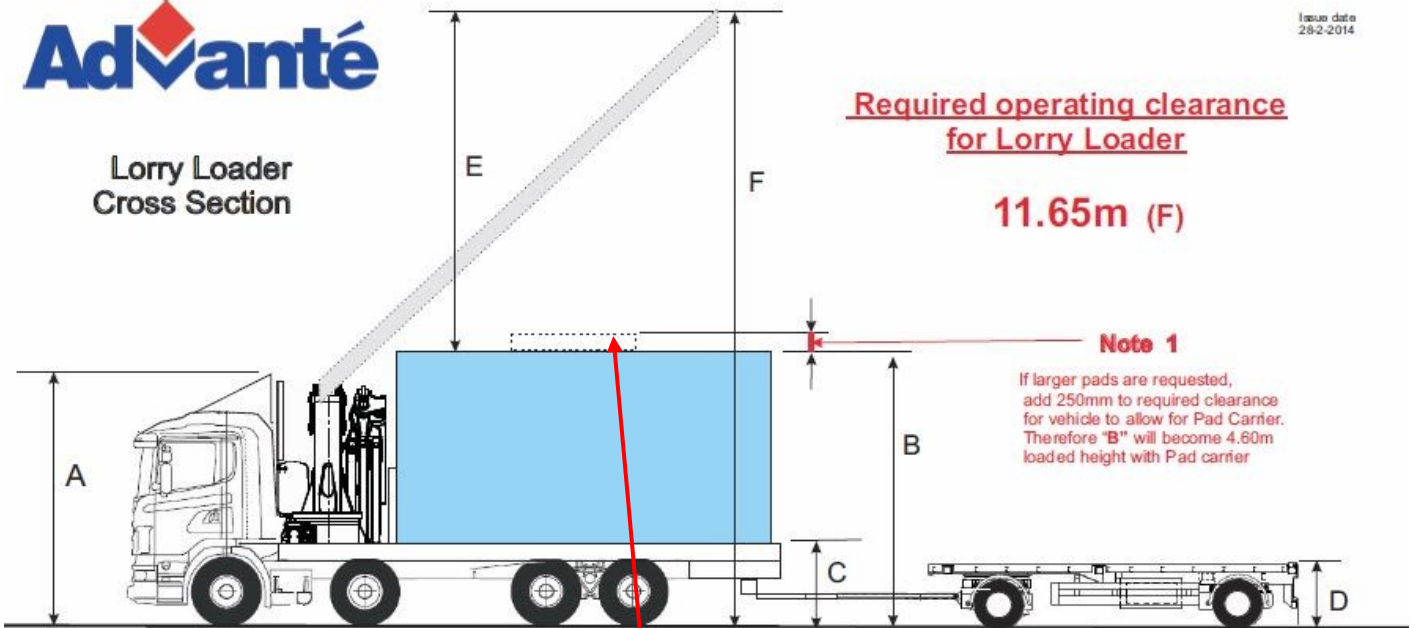

Lorry Loader height above Load					H
Unit Length (m) (2.7m wide)	Crane structure Top to Hook (m)	Master link (m)	Height to master link from unit roof (m)	Movement allowance (m)	Minimum height required above unit (m)
4.8	1.5	0.4	2.4	0.5	4.8
6.3	1.5	0.4	3.2	0.5	5.6
7.3	1.5	0.4	3.7	0.5	6.1
9.8	1.5	0.4	4.9	0.5	7.3

Lorry dimensions

- A 4.10m unloaded running height
- B 4.35m loaded height to top of unit
- C 1.25m lorry deck
- D 1.10m trailer deck

Note on B This is height for our highest unit (3.1m) other models are lower 2.65m) so dimension **A** then becomes the critical access measurement. (See Note 1 in red)
Note on F Clearance required varies according to unit size. See Table column **H** for specific dimension and add dimension **B** to **H** to obtain model specific value of **F**.

Larger Mats below available at additional cost as confirmed on the quotation provided.



3. Ground Conditions

Access/Egress:	Otherwise, suitable for vehicle configuration detailed, uninterrupted, hazard free to low-risk area UNDER escort from a Client Site Operative/Banksman. NB. The Lorry Loader Crane Operator has the right to raise any issues on arrival
Lifting Position:	Client to prepare the ground if required/accept the vehicle weight and distributed outrigger load for the standard Outrigger Mats confirmed. Suitable for uninterrupted, hazard free to low-risk area.

PRESSURE UNDER OUTRIGGER FOOT/PAD CALCULATION

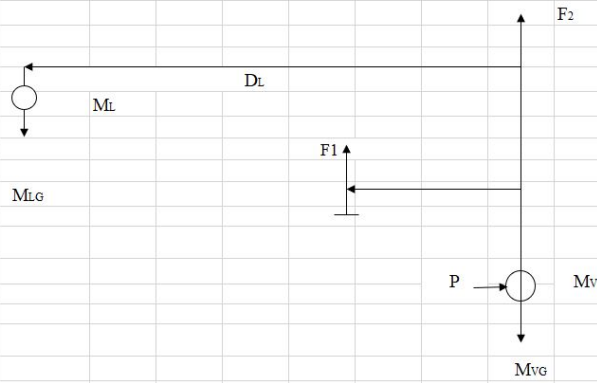

M_L = MASS OF LOAD (KG) –
 M_V = MASS OF VEHICLE (KG)
 D_F = DISTANCE FROM C/L OF COLUMN C/L OF FOOT (METRES) –
 D_L = DISTANCE FROM C/L OF COLUMN TO C/L OF LOAD (METRES) –
 (this is the maximum distance D_L will be.)
 F_1 = FORCE AT FOOT (NEWTONS)
 F_2 = FORCE AT VEHICLE (NEWTONS)
 G = FORCE OF GRAVITY (9.8 m/s^2)
 FORMULA FOR FORCE AT C/L OF FOOT, AS PARTICLE FORCE IS AS FOLLOWS:

$$F_1 = \frac{M_L G D_L}{D_F}$$

 DIVIDE F_1 BY AREA OF FOOT/PAD TO GIVE FORCE IN N/m^2

Calculations for lifting a 24 Ft EcoMax configuration Welfare Unit with 500 mm x 500 mm standard Nylon Outrigger Mats provided

Don't forget the king post on most cranes is offset so for maximum Outrigger extension the longest measurement is from the centre of the vehicle to the centre of the outrigger lift ram plus the offset. If you enter the loaders maximum lift at maximum extension this will give you the maximum pressure on an outrigger pad for any weight /radius combination possible on that vehicle

Data Table input	Enter information in yellow squares
6.3	Radius of lift from crane centre (D _L) in Metres (example 3.45)
5100	Total weight of lift including chains or other lifting equipment (M _L) in KG
3.895	Out rigger extension (D _F) in metres, plus distance to centre of king post in Metres
Pad size	Pad's under out riggers 500 by 500 mm
Standard Mat with minimum 45.97 Tonne Class Crane = 500 mm x 500 mm Nylon Mat = 0.25 Sq Metres	

Don't forget if you want to calculate the load on the pad at less than the maximum loader lift at a radius the total weight of a lift equals Load plus lifting equipment

Pressure under outrigger in N/m ²	
5100	M_L = MASS OF TOTAL LOAD (KG) –
18200	M_V = MASS OF VEHICLE (KG)
3.895	D_F = DISTANCE FROM C/L OF COLUMN C/L OF FOOT (METRES) –
6.3	D_L = DISTANCE FROM C/L OF COLUMN TO C/L OF LOAD (METRES) – (this is the maximum distance D_L will be.)
80840.56	F_1 = FORCE AT FOOT (NEWTONS)
9.8	F_2 = FORCE AT VEHICLE (NEWTONS)
0.25	G = FORCE OF GRAVITY (9.8 m/s^2)
	Foot pad 0.5 X 0.5 metre
323362	Pressure under outrigger in N/m ²
	DIVIDE F_1 BY AREA OF FOOT/PAD TO GIVE FORCE IN N/m^2
323	kN/m² 32.97 Tonnes /per M²
	This is the pressure under the Outrigger with shortest distance from the crane centre when fully extended with maximum 5100 Kgs load , therefore the maximum pressure on any surface with the confirmed Outrigger Pad

4. Lifting Accessories

Slings (Rope): N/A	Slings (Webbing): N/A
Slings (Chain): 1 No Set of 4 Leg 7 Metre Chain Brothers minimum combined SWL 7.5 Te per set fitted with Safety Hook's suitable to lift the EcoMax Unit's	Shackles: N/A
Other Accessories Used: N/A	

Lower lifting positions on the 24 Ft EcoMax Unit's – Refer to Section 1 Page 2 product details



Top Lifting Positions (All EcoMax Welfare Units)

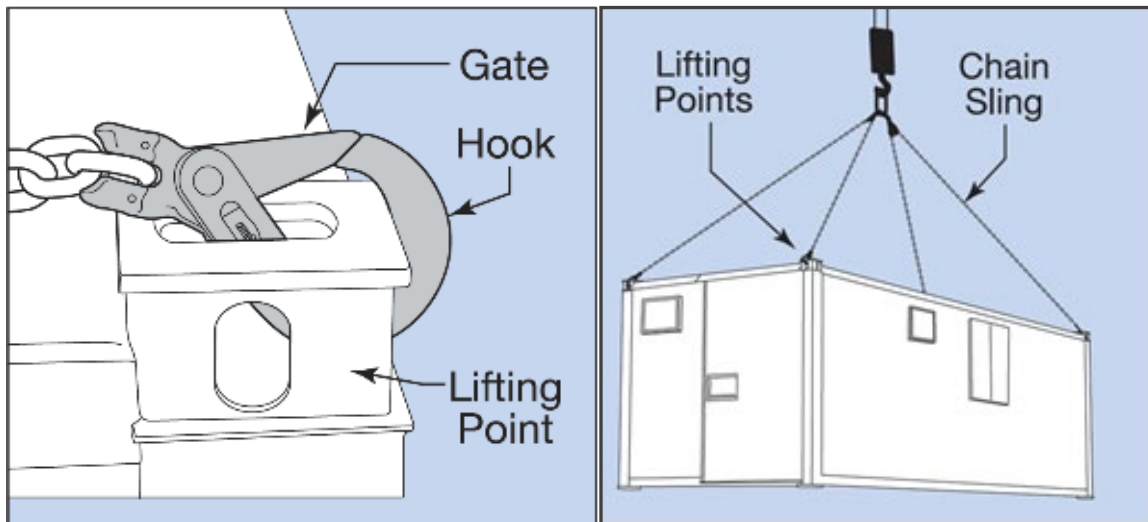

5. Hazards to be considered and assessed by Clients Site Management and confirmed prior to delivery.

Proximity Hazards	Present?	Proximity Hazards	Present?
Overhead Power Lines		Hazardous Chemicals/Materials	
Other Overhead Obstacles		Confined working Area	
Underground Services		Restricted Access - Width	
Excavations		Restricted Access - Height	
Unstable/Soft Ground		Other Vehicles	
Slinging Difficulties		Adjacent to Railway Line	
Other Hazards Identified			

6. Operational Requirements

Fall Arrest System with Auto-Descender in place for Working at Height procedures

Lorry Loader Crane Operator will operate the Lorry Loader Crane via a Waist positioned Remote Control Console working to client management approval and with client nominated operatives.

If necessary, the Lorry Loader Crane Operator can operate alone using Remote Control Console under strict control procedures to be assessed and informed to the Client. Refer to Risk Assessment Section 13

7. Customer Provisions

Client to organise and maintain all traffic control, demarcation of the working area, control of the Lorry Loader Crane and other traffic for access/egress, preparation of suitable area to receive the EcoLogic Unit(s), freely available induction if required and all welfare/operation support of Advanté staff while on site

8. Personnel:

Title	Responsibility	Required PPE
Crane Supervisor – To be provided by Client/Site Manager	Oversee all below	Hi-Vis Waist Coats or Jackets BSEN471 Toe Protection Safety Boots BSEN 346 Gloves BS1651 Safety Glasses/Goggles DIN EN166 Hard Hat BSEN 397
Slinger/Signaller Combined Role with Crane Operator	Attach/detach Lifting Chains to and from the Welfare Unit, signal the movement of the crane and load on the Crane Hook with assistance from client nominated site operatives restraining the Tag Lines	Hi-Vis BSEN471 or Jackets BSEN471 Harness – Advante Operatives use a Cradle Harness BSEN 361:2002. External Re-Hired Operatives may use alternative specifications to minimum BSEN 361 Inertia Reel BS EN 360:2002 Toe Protection Safety Boots BSEN 346 Gloves BS1651 Safety Glasses/Goggles DIN EN166 Hard Hat BSEN 397
Lorry Loader Crane Operator	Correct operation of the Lorry Loader Crane in accordance with the manufacturer’s instructions.	Hi-Vis BSEN471 or Jackets BSEN471 Toe Protection Safety Boots BSEN 346 Gloves BS1651 Hard Hat BSEN 397 Safety Glasses/Goggles DIN EN166

9. Lifting Accessories

The lifting accessories will be provided by Advanté Ltd and supported by valid Certificates of Thorough Examination.

10. Weather Conditions

The lifting operation can only take place if the weather conditions are within the limits recommended by the crane manufacturer of a maximum 13.9 M/S less an allowance for the surface area of the Welfare Unit to be lifted.

Wind speeds measured by handheld Anemometer – These devices are used for indication purposes only.

11. Ground Conditions

It is the Client's responsibility to check before the lift is undertaken to determine that the ground is suitable and as such Advanté Ltd. will not be responsible for any liabilities and / or damage to surfaces that arise from the ground conditions not being suitable to allow access / egress and lifting operations to be carried out.

12. Trading Conditions

CPA., FTA.

13. Lifting Conditions

CPA Supplementary Conditions Applicable to Mobile Cranes (Wheeled & Crawler Mounted) 2011

Sequence of Works

Note	<i>The Advanté Delivery & Collection RAMS supporting these works accompanies this Method Statement and will be valid at the point of undertaking site activities – this document is subject to regular changes and the current version will always be provided at the point of service delivery.</i>
1	Arrive at site and the Lorry Loader Crane Operator's (LLCO) will report to the Client Site Management (C SM) at the pre-arranged time above for traffic guidance and receive any updates to previously advised controls relevant to current site conditions.
2	The LLCO's will make available all Crane, Lifting Tackle, Harness and personnel/training documentation to the C SM and with the assistance from the C SM, this will be entered the Site/Safety Inspection Register to prior to any work commencing.
3	The LLCO's will liaise with the C SM and nominated Client Site Operatives (C Ops) in respect of demarking and controlling the safe working area for the operation of the individual Lorry Loader Crane (LLC) and the unloading activities corresponding with the drawing below and the maximum unloading radius confirmed in Section 1 Page 2. Note in the absence of input from the C SM/C Ops, the LLCO's will define the safe working area and Mark Out using Hatched Tape and display Hazard Warning Beacons/Lights on the LLC throughout the operation.
4	With C SM approval to proceed and displaying Hazard Warning Beacons, the LLC's will now enter the site under guidance from C Ops to the unloading position required to correspond with the maximum radius confirmed in Section 1 Page 2.
5	The LLCO and C SM will verify that no additional hazards are present within the lifting position at both ground level and overhead and that all conditions have been met as set out in the Risk Assessment & Method Statement.
6	The LLCO's to then attend (if required) the Site Induction and C SM will issue the Permit to Lift and if required, a Permit for the Use of Ladders. Included in the Induction will be the location of the nearest A & E Hospital and Non-Emergency Medical Centre and this will be included in the Action Plan to be confirmed by the C SM.
7	With C SM approval to proceed, the 1 st LLCO will then recheck that the isolated area remains clear and from an operating position on each side of the LLC, extend the Crane Stabiliser Beams to the maximum width, recheck for the position of any Utility Covers/changes in the surface to be set up on and position the standard Outrigger Mats carried on the LLC.
8	The 1 st LLCO will then extend the Outrigger Rams to stabilise the Crane ensuring the Wheels are in contact with the ground, the suspension is not completely unloaded and carry out any pre-operational checks in accordance with the manufacturer's recommendations. NB. If the additional Outrigger Mats are requested and confirmed on the official order to be received, these are delivered on the Pad Carrier (Refer to Page 5 Diagram of the Lorry) located on the roof of the Welfare Unit and will be unloaded and positioned corresponding with Item's 6 and 12 of the Risk Assessment Document.
9	The 1 st LLCO will check the weather conditions comply with the lifts to be carried out and select the Lifting Chain Leg Brothers required to lift the 24 Ft EcoMax Ground Floor Unit (GF Unit) and then control the Crane and carry out the motions required to position the Boom with the Lifting Chains above the GF Unit for attachment to the 4 No lower position Lifting Lugs. Refer to the detail on Pages 2 and 7.
10	NOTE FOR TOP LIFTING POSITIONS ONLY IF REQUIRED – The Lifting Chains will then be attached to all Four corner lifting points via the use of a Pre-Inspected Ladder (as per the RA) with the 2 nd LLCO using a Harness and Fall Arrest as per the RA. The Ladder MUST be positioned on suitable level ground and Footed by C Ops/1 st LLCO.



Hired & Managed Advisory General Method Statement – Advanté Welfare

11	Tag Line's will then be attached to each end of the GF Unit to enable C Ops/the 2 nd LLCO to control the GF Unit. The 1 st LLCO will carry out a visual check of the Lifting Chains/lifting positions, the position of the Crane Hook and check that all involved are ready and will be in a Visual or Audible position at all times throughout lifting the GF Unit.
12	With C SM approval to continue, the 1 st LLCO will control the Crane to carry out the motions required to lift the GF Unit just clear from the transport position and STOP. The 1 st LLCO will check that the GF Unit has lifted in a level position and the Lifting Chains remain secure.
13	When the checks are completed and with the GF Unit being restrained by the Tag Lines, the 1st LLCO will control the Crane and carry out the motions required to slew to the installation position required.
14	Prior to the GF Unit being lowered, a visual check of any hazards must be conducted including the positions of all personnel involved in the lifting operation and continued consideration given to any other activities on the perimeter of the isolated area.
15	Once clear/checks are completed, the GF Unit can now be lowered into position and levelled using the EcoMax Power Pad provided/any C SM provided "Packing" that is required/the adjustable feet of the GF Unit.
16	The 1st LLCO will now control the Crane to take the tension off the Lifting Chains to allow detachment from the Four lower lifting positions followed the motions required to slowly position the Lifting Chains clear of the EL Unit to prevent the Lifting Chains from Snagging.
17	NOTE FOR TOP LIFTING POSITIONS ONLY IF REQUIRED – The Lifting Chains will then be detached from the Four top corner lifting points via the use of the Pre-Inspected Ladder with the 2 nd LLCO using a Harness and Fall Arrest as per the RA. The Ladder MUST be positioned on level ground and footed by C Ops/the 1 st LLCO.
18	The 1st LLCO will now control the Crane to position the Boom over the Trailer in preparation to unload the MS. The 2nd LLCO will then position a Pre-Inspected Ladder against the Trailer on firm level ground and attach the Harness worn to the Inertia Reel to gain access on to the Trailer and attach the Lifting Chains to all lifting points of the MS. The Ladder to be Footed by the 1st LLCO/ C Ops. Refer to the Page 2 detail.
19	Tag Lines will then be attached to the MS to be controlled by the 2 nd LLCO and with C SM approval to continue, the 1 st LLCO will control the Crane to carry out the motions required to lift the MS from the Trailer, slew over and "Lock" into the end Twist Locks of the GF Unit.
20	The 1 st LLCO will now control the Crane and carry out the motions required to position the Boom over the MS and attach the Harness worn to the Inertia Reel. The 1 st LLCO will then install all Handrails on the MS before ascending to the top to detach the Lifting Chains from all the lifting points.
21	The 1st LCCO will now control the Crane and position the end of the Boom and the Inertia Reel over the Generator end of the GF Unit. The 2nd LCCO will attach the Harness worn to the Inertia Reel and with use of a Pre-Inspected Ladder (as per the RA) place a Twist Lock into one of the top lifting eyes. The Ladder MUST be positioned on suitable level ground and Footed by C Ops/the 1st LLCO. Repeat for the 2nd Twistlock to be positioned.
22	The 1st LLCO will then control the Crane to carry out the motions required to position the Lifting Chains clear of the GF Unit to prevent the Lifting Chains from Snagging and then derig the Crane in accordance with the manufacturer's recommendations. Under guidance from C Ops, the LLC will be moved out of the working area to safely park up.

23	Working with the C Ops, the 1st LLCO will assist with guidance of the 2nd LLC into a position confirmed On the Drawing to allow the first-floor level EM700 EcoMax Unit (EM Unit) to be unloaded and provide the Double stacked configuration confirmed on Page 2.
24	Repeat Operations 7 and 8 relevant to preparing the 2 nd LLC in accordance with the manufacturer's recommendations to lift the EM Unit.
25	The 2 nd LLCO will control the Crane and carry out the motions required to position the Boom with the Lifting Chains for attachment to the 4 No lower position Lifting Lugs. Refer to the detail on Pages 2 and 7.
26	Tag Line's will then be attached to each end of the EM Unit to enable C Ops/the 1 st LLCO to control the EM Unit. The 2 nd LLCO will carry out a visual check of the Lifting Chains/lifting positions, the position of the Crane Hook and check that all involved are ready and will be in a Visual or Audible position at all times throughout lifting the EM Unit.
27	With C SM approval to continue, the 2 nd LLCO will control the Crane to carry out the motions required to lift the EM1700 just clear of the transport and then STOP. The 2 nd LLCO will check that the EM Unit has lifted in a level position and the Lifting Chains remain secure.
28	When the checks are completed, the 2 nd LLCO will continue to position where C Ops remain in visual contact at all times and are audible to further instructions whilst the EM Unit is being lifted. The 2 nd LLCO will then control the Crane to carry out the motions required to lift the EM Unit clear of the transport and with C Ops/the 1 st LLCO restraining the Tag Lines slew to the installation position required.
29	Prior to the EM Unit being lowered, a visual check of any hazards must be conducted and continued consideration given to any other activities on site. Once clear/checks are completed, the EM Unit can now be lowered into position and "Locked In" to the GF Unit.
30	When the EM Unit is safe and secured on to the GF Unit below, the 2nd LLCO will now control the Crane to take the tension off the Lifting Chains and Operations 16 or 17 will be repeated relevant to the 1st LLCO releasing the Lifting Chains from either the Lower Level or TOP LIFTING POSITIONS, respectively.
31	The 2nd LCCO will now control the Crane and position the end of the Boom and the Inertia Reel over the Generator end of the GF Unit and Operation 21 will be repeated relevant to the 1st LLCO being able to connect the Power/Gas.
32	The 2 nd LLCO will then control the Crane to carry out the motions required to position the Lifting Chains clear of the EM Unit to prevent the Lifting Chains from Snagging.
33	On completion of the lifting operations, the 2 nd LLCO will then stow away the lifting tackle used and complete the derig procedures of the Crane as per the manufacturers recommended instructions.
34	The LLCO's will carry out checks in preparation to leave site and under guidance from C Ops, the individual LLC's will be escorted back to the site entrance and out of the Public Road system to leave safely in the direction required.
35	For collection of the EcoMax Unit's, repeat Operations 1 to 34 in a sequence relevant to removing the Units and with a competent person disconnecting the Power/Gas before lifting takes place.



Hired & Managed Advisory General Method Statement – Advanté Welfare