

## Scope

The scope of this General Method Statement is to provide an advisory document to confirm a sequenced statement of work for our arrival on site and delivery of an Advante EcoMax Dryer Welfare Unit in conjunction with client managed resources and site lifting plan requirements.

Our planning and controls have been developed in accordance with BS7121: 2016 Part 4 covering the provision of Hired & Managed Lifting operations in accordance with client Lifting Plans.

The sequencing outlined provides guidance on each step of this process from arrival on site, interaction with site resource, positioning of the vehicle for lifting and exiting the site post completion of the delivery.

In preparation for the new Civil Aviation Authority CAP 1096 Guidance Implementation which will occur not earlier than 1<sup>st</sup> April 2022, please notify Advante Ltd if there are Aerodromes, Helipads or Private Landing Strips in the vicinity of the location of the enquiry and Advante Ltd can advise on the notification process that the CAA will expect the Crane user to comply with based on the document link below.

<https://www.cpa.uk.net/news/caa-cap-1096-guidance-for-crane-users-and-associated-cpa-tin>

Collection of the EcoMax Dryer Unit will follow the same process. This may require interaction with Advanté in advance of the planned collection date with the site resource to highlight any differences in site conditions and access that have taken place after the original delivery.

We will ensure that all lifting information including records of competence and lifting equipment inspection and test are available for the client to review and assess on site.

## Abbreviations used in this document.

LLCO – Lorry Loader Crane Operator

LLC – Lorry Loader Crane

C SM – Client Site Management referring directly to the receiver of this document

C Ops – Client Site Operatives organised by the C SM

RA – Risk Assessment

EMD Unit – EcoMax Dryer Unit



Corner loadings for the intended position/condition of the surface to be used

					
Version 1 1-3-2018					
<b>Calculation for 4.88 Metre (16 Ft) EcoMax Dryer Unit levelled on the Corner Post 184 x 164 mm Fabrications</b>					
		EcoLogic Max Weight 3750 Kgs. Heaviest end of Unit Max 2300 Kgs		2300	
Load per leg/Corner	1150	<b>Total load per leg in KG</b>			
		Pad's/base plate size under legs		184	by 164 mm
<b>Pressure under each jackleg in N/m<sup>2</sup></b>					
1150	M <sub>L</sub> = MASS OF TOTAL LOAD (KG) –				
11270	FORCE AT FOOT (NEWTONS) PER LEG WITHOUT PAD'S				
9.8	G = FORCE OF GRAVITY (9.8 m/s <sup>2</sup> )				
0.030176	Foot pad	0.184 x	0.164 metre		
<b>373476</b>	Pressure under base pad in N/m <sup>2</sup>				
<b>DIVIDE F<sub>1</sub> BY AREA OF FOOT/PAD TO GIVE FORCE IN N/m<sup>2</sup></b>					
<b>373</b>	<b>kN/m<sup>2</sup></b>	This is the pressure under one of the legs (the pair being equally loaded) at the staircase end of the unit, which is therefore maximum load on any one jackleg of the 4 base pads on which complex stands.			

## 2. Details of Vehicle/Crane

Make & Model:	Rigid Scania 8 x 2 with minimum 45.97 Te Metre Class Fassi F455RA 2.25 Lorry Loader Crane
Capacity:	41.79 Te/Metre – Substitute Crane suitable for the weight and radius confirmed in Section 1
Outrigger Spread Centres:	Left to Right (X) Max 8.2 Metre Front to Back (Y) 7.3 Metres
Force through Outrigger Piston.	61026 Newton's – Refer to Page 7
Standard Mat/Pad Size:	 <p>500 mm x 500 mm Nylon Mats = 0.25 Sq M</p>
Additional Outrigger Mat's available at additional cost:	Please refer to the quotation provided - 1.5 M x 1.2 M available.
Final maximum distributed Outrigger Load with standard Mat:	24.89 Te M Sq – Refer to Page 7
Gross Rigged Weight:	28,000 Kgs



Lorry Loader  
Cross Section

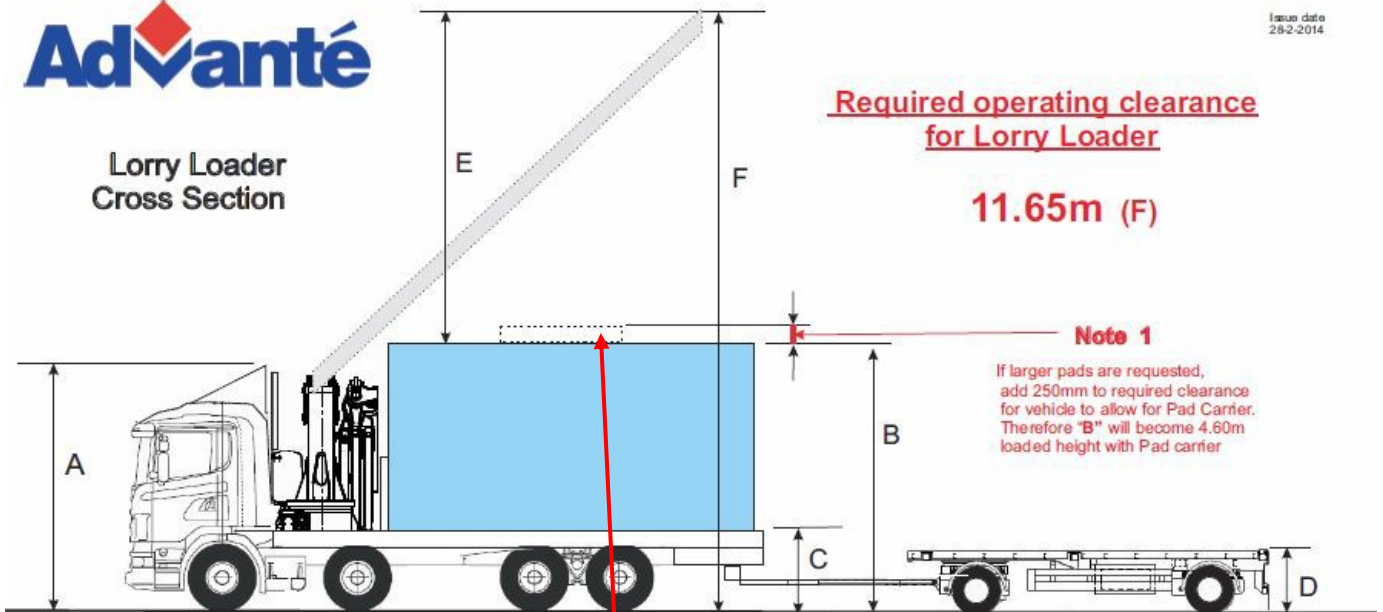

**Required operating clearance  
for Lorry Loader**

**11.65m (F)**

**Note 1**

If larger pads are requested, add 250mm to required clearance for vehicle to allow for Pad Carrier. Therefore "B" will become 4.60m loaded height with Pad carrier

Lorry Loader height above Load					H
Unit Length (m) (2.7m wide)	Crane structure Top to Hook (m)	Master link (m)	Height to master link from unit roof (m)	Movement allowance (m)	Minimum height required above unit (m)
4.8	1.5	0.4	2.4	0.5	4.8
6.3	1.5	0.4	3.2	0.5	5.6
7.3	1.5	0.4	3.7	0.5	6.1
9.8	1.5	0.4	4.9	0.5	7.3

**Lorry dimensions**

- A 4.10m unloaded running height
- B 4.35m loaded height to top of unit
- C 1.25m lorry deck
- D 1.10m trailer deck

**Note on B** This is height for our highest unit (3.1m) other models are lower (2.65m) so dimension A then becomes the critical access measurement. (See Note 1 in red)  
**Note on F** Clearance required varies according to unit size. See Table column H for specific dimension and add dimension B to H to obtain model specific value of F.

**Larger Mats below available at additional cost as confirmed on the quotation provided.**



**FASSI**

**F455RA.2.25 e-dynamic - Load Diagram**

Via Roma, 110  
14021 Albino (BG)  
Tel.: +39 035 776400  
Fax: +39 035 755020  
www.fassi.com  
fassi@fassi.com

LOAD DIAGRAM WITH LIFTING MOMENT LIMITING DEVICE

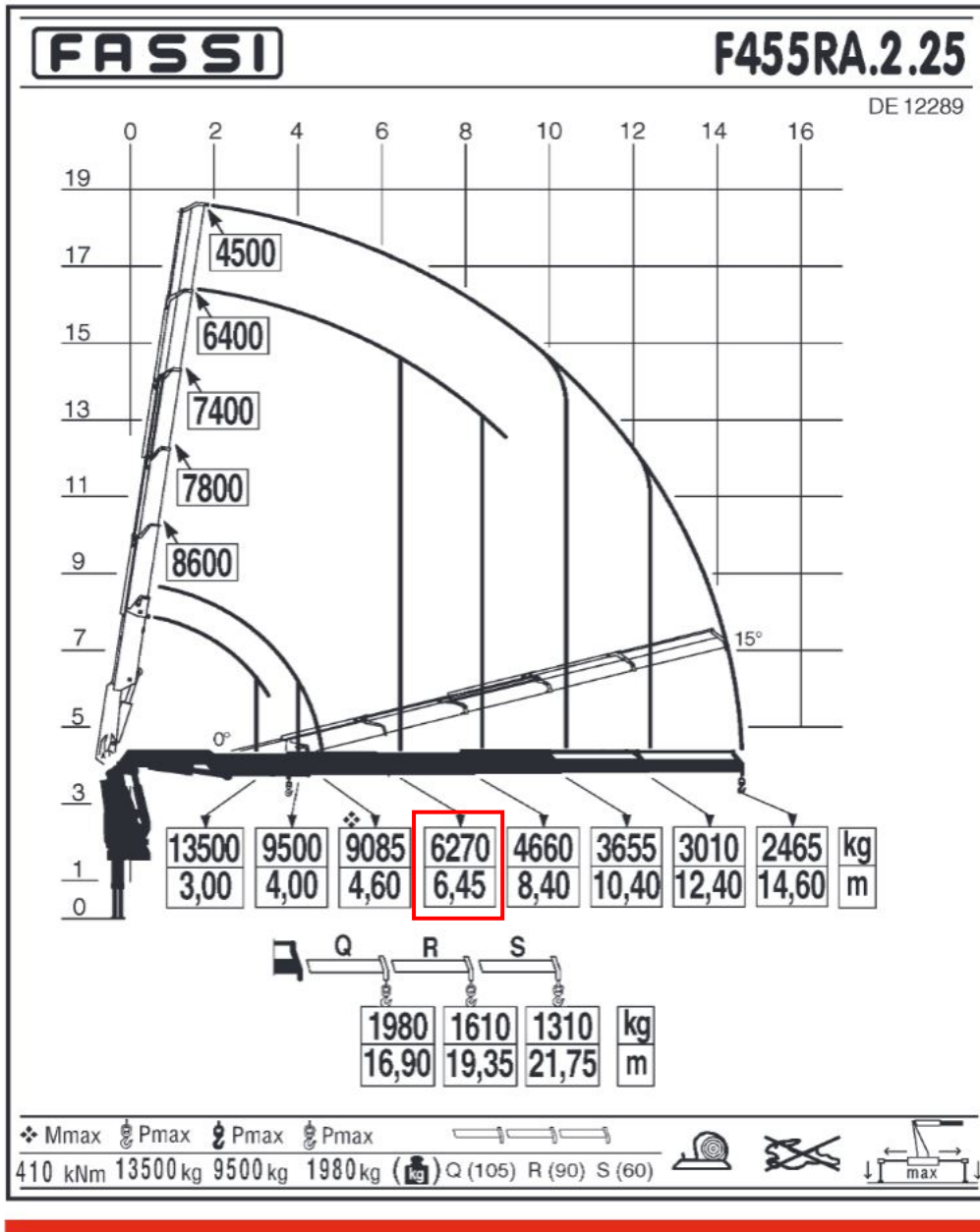

### 3. Ground Conditions

Access/Egress:	Otherwise, suitable for vehicle configuration detailed, uninterrupted, hazard free to low-risk area UNDER escort from a Client Site Operative/Banksman. NB. The Lorry Loader Crane Operator has the right to raise any issues on arrival
Lifting Position:	Client to prepare the ground if required/accept the vehicle weight and distributed outrigger load for the standard Outrigger Mats confirmed. Suitable for uninterrupted, hazard free to low-risk area.

**PRESSURE UNDER OUTRIGGER FOOT/PAD CALCULATION**

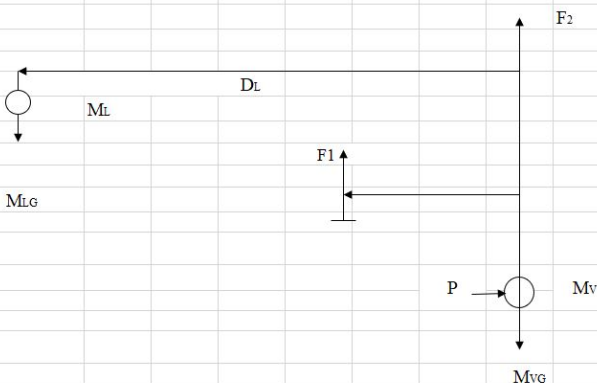

$M_L$  = MASS OF LOAD (KG) –  
 $M_V$  = MASS OF VEHICLE (KG)  
 $D_F$  = DISTANCE FROM C/L OF COLUMN C/L OF FOOT (METRES) –  
 $D_L$  = DISTANCE FROM C/L OF COLUMN TO C/L OF LOAD (METRES) –  
 (this is the maximum distance  $D_L$  will be.)  
 $F_1$  = FORCE AT FOOT (NEWTONS)  
 $F_2$  = FORCE AT VEHICLE (NEWTONS)  
 $G$  = FORCE OF GRAVITY ( $9.8 \text{ m/s}^2$ )  
 FORMULA FOR FORCE AT C/L OF FOOT, AS PARTICLE FORCE IS AS FOLLOWS:  

$$F_1 = \frac{M_L G D_L}{D_F}$$
  
 DIVIDE  $F_1$  BY AREA OF FOOT/PAD TO GIVE FORCE IN  $\text{N/m}^2$

19-11-2010 ver3

### Calculations for lifting a 16 Ft EcoMax Dryer Welfare Unit

#### with minimum size 500 mm x 500 mm Outrigger Mats provided

Don't forget the king post on most cranes is offset so for maximum Outrigger extension the longest measurement is from the centre of the vehicle to the centre of the outrigger lift ram plus the offset. If you enter the loaders maximum lift at maximum extension this will give you the maximum pressure on an outrigger pad for any weight /radius combination possible on that vehicle

Data Table input	Enter information in yellow squares
6.3	Radius of lift from crane centre ( $D_L$ ) in <b>Metres</b> (example 3.45)
3850	Total <b>weight</b> of lift including chains or other lifting equipment ( $M_L$ ) in <b>KG</b>
3.895	Out rigger extension ( $D_L$ ) in metres, plus distance to centre of king post in Metres
<b>Pad size</b>	Pad's under outriggers <b>500</b> by <b>500</b> <b>mm</b>
Standard Mat with minimum 45.97 Te Metre Class Crane = 500 mm x 500 mm Nylon Disc = 0.25 Sq Metres	

Don't forget if you want to calculate the load on the pad at less than the maximum loader lift at a radius the total weight of a lift equals Load plus lifting equipment

Pressure under outrigger in $\text{N/m}^2$			
3850	$M_L$ = MASS OF TOTAL LOAD (KG) –		
24300	$M_V$ = MASS OF VEHICLE (KG)		
3.895	$D_F$ = DISTANCE FROM C/L OF COLUMN C/L OF FOOT (METRES) –		
6.3	$D_L$ = DISTANCE FROM C/L OF COLUMN TO C/L OF LOAD (METRES) – (this is the maximum distance $D_L$ will be.)		
61026.70	$F_1$ = FORCE AT FOOT (NEWTONS)		
9.8	$F_2$ = FORCE AT VEHICLE (NEWTONS)		
0.25	$G$ = FORCE OF GRAVITY ( $9.8 \text{ m/s}^2$ )		
	Foot pad	0.5 X	0.5 metre
<b>244107</b>	Pressure under outrigger in $\text{N/m}^2$		
	<b>DIVIDE <math>F_1</math> BY AREA OF FOOT/PAD TO GIVE FORCE IN <math>\text{N/m}^2</math></b>		
<b>244</b>	<b>kN/m<sup>2</sup></b>	<b>24.89</b>	<b>Tonnes /per M2</b>
			This is the pressure under the Outrigger with shortest distance from the crane centre when fully extended with maximum 3850 Kgs load, therefore the maximum pressure on any surface with the confirmed Outrigger Pad

**4. Lifting Accessories**

Slings (Rope): N/A	Slings (Webbing): N/A
Slings (Chain): 1 No Set of 4 Leg minimum 6 Metre Chain Brothers, minimum combined SWL 7.5 Te per set fitted with Safety Hook's suitable to lift the EcoMax Dryer Unit	Shackles: N/A
Other Accessories Used: N/A	

**Lower lifting positions on the 16 Ft EcoMax Dryer Welfare Unit – Refer to Section 1 Page 2 product details**



**Top Lifting Positions (All Oasis Welfare Units)**

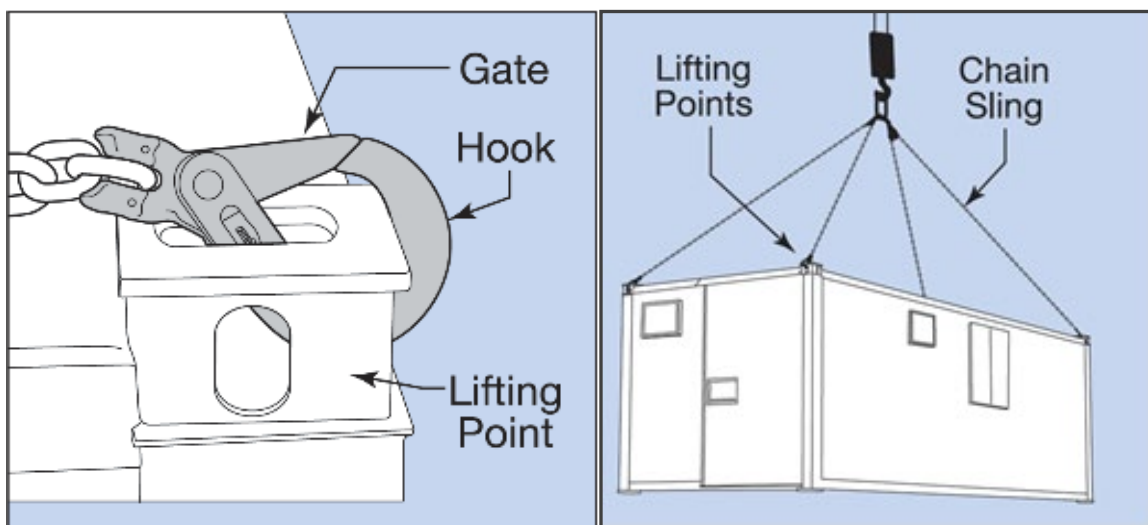

**5. Hazards to be considered and assessed by Clients Site Management and confirmed prior to delivery.**

<b>Proximity Hazards</b>	<b>Present?</b>	<b>Proximity Hazards</b>	<b>Present?</b>
Overhead Power Lines		Hazardous Chemicals/Materials	
Other Overhead Obstacles		Confined working Area	
Underground Services		Restricted Access - Width	
Excavations		Restricted Access - Height	
Unstable/Soft Ground		Other Vehicles	
Slinging Difficulties		Adjacent to Railway Line	
Other Hazards Identified			

**6. Operational Requirements**

Fall Arrest System with Auto-Descender in place for Working at Height procedures

Lorry Loader Crane Operator will operate the Lorry Loader Crane via a Waist positioned Remote Control Console working to client management approval and with client nominated operatives.

If necessary, the Lorry Loader Crane Operator can operate alone using Remote Control Console under strict control procedures to be assessed and informed to the Client. Refer to Risk Assessment Section 13

**7. Customer Provisions**

Client to organise and maintain all traffic control, demarcation of the working area, control of the Lorry Loader Crane and other traffic for access/egress, preparation of suitable area to receive the EcoLogic Unit(s), freely available induction if required and all welfare/operation support of Advanté staff while on site

### 8. Personnel:

Title	Responsibility	Required PPE
Crane Supervisor – To be provided by Client/Site Manager	Oversee all below	Hi-Vis Waist Coats or Jackets BSEN471 Toe Protection Safety Boots BSEN 346 Gloves BS1651 Safety Glasses/Goggles DIN EN166 Hard Hat BSEN 397
Slinger/Signaller  Combined Role with Crane Operator	Attach/detach Lifting Chains to and from the Welfare Unit, signal the movement of the crane and load on the Crane Hook with assistance from client nominated site operatives restraining the Tag Lines	Hi-Vis BSEN471 or Jackets BSEN471 Harness – Advante Operatives use a Cradle Harness BSEN 361:2002. External Re-Hired Operatives may use alternative specifications to minimum BSEN 361 Inertia Reel BS EN 360:2002 Toe Protection Safety Boots BSEN 346 Gloves BS1651 Safety Glasses/Goggles DIN EN166 Hard Hat BSEN 397
Lorry Loader Crane Operator	Correct operation of the Lorry Loader Crane in accordance with the manufacturer’s instructions.	Hi-Vis BSEN471 or Jackets BSEN471 Toe Protection Safety Boots BSEN 346 Gloves BS1651 Hard Hat BSEN 397 Safety Glasses/Goggles DIN EN166

### 9. Lifting Accessories

The lifting accessories will be provided by Advanté Ltd and supported by valid Certificates of Thorough Examination.

### 10. Weather Conditions

The lifting operation can only take place if the weather conditions are within the limits recommended by the crane manufacturer of a maximum 13.9 M/S less an allowance for the surface area of the Welfare Unit to be lifted.

Wind speeds measured by handheld Anemometer – These devices are used for indication purposes only.

### 11. Ground Conditions

It is the Client's responsibility to check before the lift is undertaken to determine that the ground is suitable and as such Advanté Ltd. will not be responsible for any liabilities and / or damage to surfaces that arise from the ground conditions not being suitable to allow access / egress and lifting operations to be carried out.

### 12. Trading Conditions

CPA., FTA.

### 13. Lifting Conditions

CPA Supplementary Conditions Applicable to Mobile Cranes (Wheeled & Crawler Mounted) 2011

## Sequence of Works

Note	<i>The Advanté Delivery &amp; Collection RAMS supporting these works accompanies this Method Statement and will be valid at the point of undertaking site activities – this document is subject to regular changes and the current version will always be provided at the point of service delivery.</i>
1	Arrive at site and the Lorry Loader Crane Operator (LLCO) will report to the Client Site Management (C SM) at the pre-arranged time above for traffic guidance and receive any updates to previously advised controls relevant to current site conditions.
2	The LLCO will make available all Crane, Lifting Tackle, Harness and personnel/training documentation to the C SM and with the assistance from the C SM, this will be entered the Site/Safety Inspection Register prior to any work commencing.
3	The LLCO will liaise with the C SM and nominated Client Site Operatives (C Ops) in respect of demarking and controlling the safe working area for the operation of the Lorry Loader Crane (LLC) and the unloading activities corresponding with the maximum unloading radius confirmed in Section 1 Page 2. Note in the absence of input from the C SM/C Ops, the LLCO will define the safe working area and Mark Out using Hatched Tape and display Hazard Warning Beacons/Lights on the LLC throughout the operation.
4	With C SM approval to proceed and displaying Hazard Warning Beacons, the LLC will now enter the site under guidance from C Ops.
5	The LLCO and C SM will verify that no additional hazards are present within the lifting position at both ground level and overhead and that all conditions have been met as set out in the Risk Assessment & Method Statement.
6	The LLCO to then attend (if required) the Site Induction and C SM will issue the Permit to Lift and if required, a Permit for the Use of Ladders. Included in the Induction will be the location of the nearest A & E Hospital and Non-Emergency Medical Centre and this will be included in the Action Plan to be confirmed by the C SM.
7	With C SM approval to proceed, the LLCO will then recheck that the isolated area remains clear and from an operating position on each side of the LLC, extend the Crane Stabiliser Beams to the maximum width, recheck for the position of any Utility Covers/changes in the surface to be set up on and position the standard Outrigger Mats carried on the LLC.
8	The LLCO will then extend the Outrigger Rams to stabilise the Crane ensuring the Wheels are in contact with the ground, the suspension is not completely unloaded and carry out any pre-operational checks in accordance with the manufacturer's recommendations. NB. If the additional Outrigger Mats are requested and confirmed on the official order to be received, these are delivered on the Pad Carrier (Refer to Page 5 Diagram of the Lorry) located on the roof of the Oasis Unit and will be unloaded/positioned as confirmed in Item's 6 and 12 of the Risk Assessment Document.
9	The LLCO will check the weather conditions comply with the lifts to be carried out and select the Lifting Chain Leg Brothers required to lift the EcoMax Dryer Unit. (EMD Unit)
10	The LLCO will then control the Crane and carry out the motions required to position the Boom with the Lifting Chains above the EMD Unit for attachment to all Four lower position lifting points. Refer to the detail on Page's 2 and 7.

11	NOTE FOR TOP LIFTING POSITIONS ONLY IF REQUIRED – The Lifting Chains will then be attached to all four corner lifting points via the use of a Pre-Inspected Ladder (as per the RA) and using a Harness and Fall Arrest as per the RA. The Ladder MUST be positioned on level ground and footed by C Ops.
12	Tag Line's will then be attached to each end of the EMD Unit to enable C Ops/the LLCO to control the EMD Unit. The LLCO will carry out a visual check of the Lifting Chains/lifting positions, the position of the Crane Hook and check that all involved are ready and will be in a Visual or Audible position at all times throughout lifting the EMD Unit.
13	With the C SM approval to continue, the LLCO will control the Crane to carry out the motions required to lift the EMD Unit just clear from the transport position and STOP. The LLCO will check that the EMD Unit has lifted in a level position and the Lifting Chains remain secure.
14	When the checks are completed and with the EMD Unit being restrained by the Tag Lines, the LLCO will control the Crane and carry out the motions required to slew to the installation position required.
15	Prior to the EMD Unit being lowered, a visual check of any hazards must be conducted including the positions of all personnel involved in the lifting operation and continued consideration given to any other activities on the perimeter of the isolated area.
16	Once clear/checks are completed, the EMD Unit can now be lowered into position and levelled using any C SM provided "Packing" that is required/the adjustable feet of the EMD Unit. Refer to the Page 4 Corner Loadings applicable to the EcoMax Dryer Unit being supplied.
17	The LLCO will now control the Crane to take the tension off the Lifting Chains that will then be detached from the Four lower lifting positions. The LLCO will then control the Crane to carry out the motions required to position the Lifting Chains clear of the EMD Unit to prevent the Lifting Chains from Snagging.
18	NOTE FOR TOP LIFTING POSITIONS ONLY IF REQUIRED – The Lifting Chains will then be detached from the four corner lifting points via the use of the Pre-Inspected Ladder and using a Harness and Fall Arrest as per the RA. The Ladder MUST be positioned on level ground and footed by C Ops.
19	The LLCO will then stow away the Lifting Chains used and complete the derig procedures of the Crane as per the manufacturers recommended instructions ensuring that the working area remains isolated whilst the individual Outrigger Pistons are rotated back into the vertical position and the Stabiliser Beams are retracted back into the vehicle for the travel position.
20	The LLCO will carry out checks in preparation to leave site and under guidance from C Ops, the LLC will be escorted back to the site gates and out on to the established road system to then leave safely in the direction required.



## Hired & Managed Advisory General Method Statement – Advanté Welfare